

Register your New Fleming Product @
<http://www.fleming-agri.co.uk/Products/product-registration.asp>

EU CERTIFICATE OF CONFORMITY

CONFORMING TO EC Machinery Directive 98/37 EC

We:

Fleming Agri-Products Ltd
Newbuildings Industrial Estate
Newbuildings
Northern Ireland
BT47 2SX



declare in sole responsibility, that the product

Type: TOP7SF 7' SuperFloat Topper
TOP8SF 8' SuperFloat Topper

to which this certificate applies, conforms to the basic safety
and health requirements of the EC Machinery Directive 98/37 EC,
and the Transposed Harmonised Standards:

BS EN 745 (1999)
BS EN 1553 (2000)

Jonathan Lecky
Production Director



TOP8SF & TOP7SF
7' & 8' SuperFloat Pasture Toppers
Operators Manual
& Parts List

Fleming Agri-Products Ltd
Newbuildings Industrial Estate
Newbuildings
Northern Ireland
BT47 2SX

Tel: (028) 7134 2637

Fax: (028) 7134 4735

Email: info@fleming-agri.co.uk

www.fleming-agri.co.uk

'Quality, Strength & Personal Service'

This manual is provided to assist you in getting the best results from your machine and ensure that you do so safely. If you have any queries about the use of the machine contact your dealer before use. Please keep this manual for future reference.

This topper has been designed to be easily and safely transported behind a tractor while also giving an even and clean cut on uneven ground by being fully offset with bi-lateral movement when in the topping position. The dual heavy-duty rotors with swinging blade system allow the topper to withstand the excessive pressures of wet conditions and to absorb small impacts without affecting performance.

A hydraulic breakaway system ensures that any damage to your machine following an impact with a larger obstruction is dramatically reduced. The operating position is quickly restored without hassle ensuring minimum operator inconvenience.

The cutting height is adjustable in convenient steps from the minimum depth of 30mm to a maximum depth of 120mm. The depth is easily adjusted by altering the position of the skids which are positioned at each side of the topper. These skids ensure that the topper provides a uniform cut without grounding while on the most undulating pastures.

This topper will successfully operate in wet conditions and on heavy pasture such as rushes, however it is unsuitable for topping set-aside. While this topper is primarily designed for agricultural use it performs excellently when used for topping playing fields or other local authority areas.

1.1 FUNDAMENTAL PRECAUTIONS

On delivery, your dealer gave you an explanation of the operation and maintenance of this Fleming topper. Please read and understand these operating instructions before operating the machine for the first time. It is essential that you observe all safety instructions.

Incorrect use or mishandling of the machine can endanger:

- Life and Limb of the operator, other persons or animals standing within the vicinity of the machine.
- The machine and other material assets of the owner or third persons.
- The performance of the machine.

Anyone who is involved in the commissioning, operation or maintenance of the topper must read and understand the following instructions very carefully and observe them at all times.

NEVER DISTRACT ANYONE WHO IS USING A MACHINE.

A SAFE DISTANCE OF AT LEAST 30M MUST BE OBSERVED BY ANYONE WITHIN THE VICINITY OF THE TOPPER.

1.2 AUTHORISED OPERATORS

Youths under the age of 16 must not operate this implement. The owner of the machine must provide the operator with the operating instructions and make sure they have read and understood them. Only then may the topper be put into operation.

The owner must ensure that only authorised persons operate/work on this machine. He is responsible for keeping any third persons or animals out of the working area of the topper.

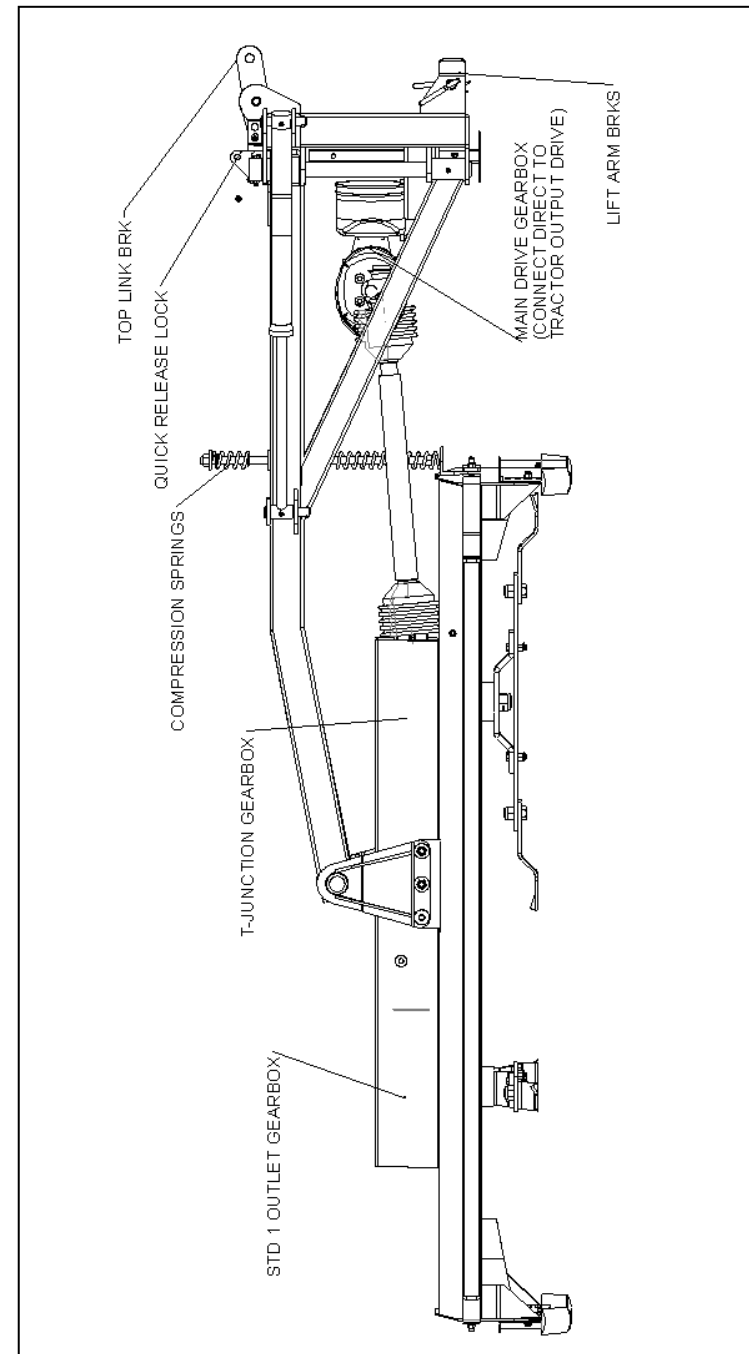

1.3 GENERAL SAFETY AND ACCIDENT PREVENTION REGULATIONS

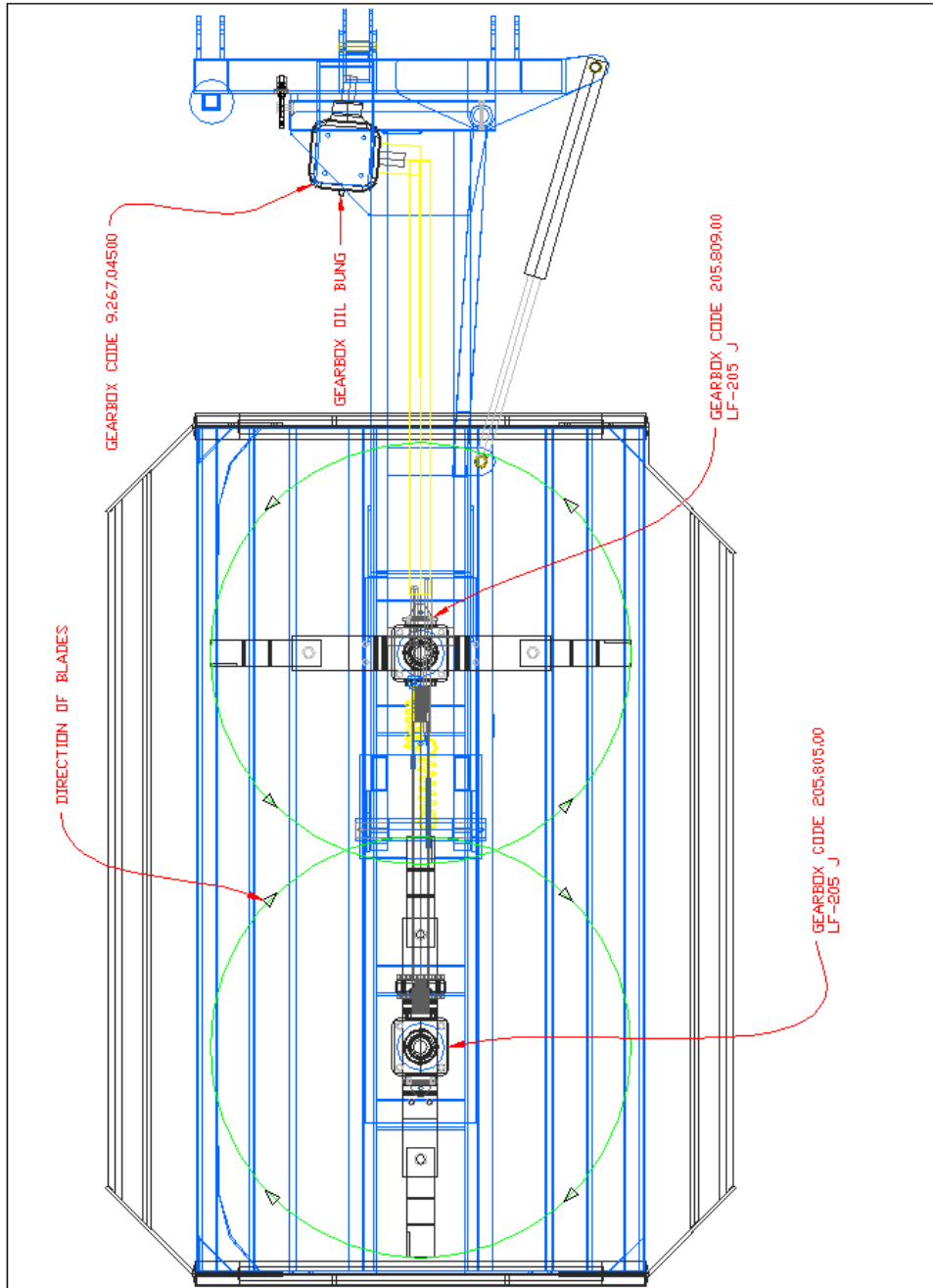

- Ensure the implement is correctly and securely attached to the operating vehicle 3-point linkage using the lift arm pins and locking lynch pins provided.
- NEVER** attach to a tractor which would be rendered unstable when the implement is operated at its full capacity. Take note of the maximum load permissible on the linkage. The weight of the 7ft model is 616kg and the 8ft model is 650kg.
- Extra care must be taken as the implement can cause instability due to the projection out the rear or the side of the tractor.
- Take extra care when operating machinery on sloping ground. **NEVER** operate on ground on which there is a risk of the tractor becoming unstable.
- When detaching the implement from the tractor always ensure that it is stable and is safely positioned on a level surface.
- WARNING:** The attaching and detaching of the implement to a tractor must be carried out by only one operator. There should not be any other people in the vicinity of the implement or in the tractor.
- ALWAYS** ensure that the rope attaching the locking mechanism to the tractor is detached and safely stored before detaching the implement from the tractor.
- WARNING** Extra care must be taken when operating or transporting the topper as it extends significantly out the rear or side of the tractor.
- ENSURE** that the topper is locked in the transport position when on a road and when it is being attached and detached from the tractor.
- ONLY** operate the locking mechanism from the cab and ensure that the area which the topper will rotate into is clear before doing so.
- Before operation make yourself familiar with all elements and controls of the machine as well as their functions.
- Under NO Circumstances** should anyone attempt to use the topper or the three point linkage as a means of personal transport. It is designed as a specialist purpose farm implement and is unsuitable for the safe transportation of passengers. To avoid personal injury do not allow hands or limbs to enter the area between the hitch and main body.
- NEVER** allow children to play on or around tractors and machinery.
- Operators should not wear loose fitting clothing when working close to PTO driven equipment. Keep long hair tied back. **NEVER** be in the vicinity of a rotating PTO shaft.
- ALWAYS** disengage the PTO before dismounting from the tractor.
- NEVER** operate the topper unless all safety guards are fitted and are firmly in position. **ALWAYS** ensure that all guards and covers are replaced after carrying out maintenance or adjustments.
- ALWAYS** disengage the PTO shaft, apply the hand brake, stop the tractor and remove the key before carrying out any maintenance or adjustments to the topper. The blades continue to rotate for some time after the tractor is stopped. **ALWAYS** ensure that the blades have totally stopped moving before approaching the topper.

- NEVER** attempt to adjust the skids without the topper being in a stable and safe position.

- Take extra care when carrying out maintenance and adjustments, as this is when most farm accidents occur.

- ENSURE** the PTO shaft is the correct length to suit the tractor.

- ALWAYS** ensure that the PTO tubes and universal joints have sufficient grease.

- Regularly check the PTO shaft and guard for damage and replace if any damage is found.

- ALWAYS** use 8mm shear bolts with a rating of 8.8 on the knuckle joint. Standard bolts or shear bolts with a rating greater than 8.8 may cause undue stress to the topper and risk life and limb.

- NEVER** attempt to move this implement manually.

- NEVER** change the release pressure on the Breakaway valve unless authorised to do so by FLEMING AGRI-PRODUCTS.

1.4 GENERAL OPERATING INSTRUCTIONS

- This is a tractor-mounted implement. Attempts should not be made to attach the topper to any other type of vehicle. If the topper is to be transported on a trailer then it should be securely attached using suitable restraints.

- Never use incorrectly sized lift arm or top link pins when attaching the topper. Ensure top link has sufficient adjustment to facilitate correct setting of the topper.

- Fit the topper to the three-point linkage in the normal way. Ensure that the PTO is correctly connected before use.

- When the implement is attached to the tractor the stand should be raised to its highest setting. When detaching from the tractor the stand should be set at a suitable height.

- Fit PTO shaft in the transport position to ensure the correct length.

- ENSURE** the restraining chains on the PTO cover are attached to the holes provided on the fixed guards and on the tractor PTO guard.

- Adjust the topping height by removing the 4 bolts on each skid and set to the required height. Only adjust the height when the topper is in the topping position and is on stable ground. **ENSURE TRACTOR IS STOPPED, THE BLADES HAVE STOPPED MOVING AND THE TOPPER IS SUITABLY SUPPORTED.**

- DO NOT ENGAGE THE PTO WHEN IN THE TRANSPORT POSITION.**

- Attach a suitable length of rope to the eye on the locking mechanism so that it can be operated safely from the cab. Ensure that the length of the rope used allows the free movement of the implement from the maximum to minimum heights and that there is no possibility of the slack rope becoming entangled and risking life or limb.

- Ensure the working area is clear of stones or anything which may cause damage to the topper or increase the danger to life and limb.

- With the PTO shaft, Hydraulic pipes and all safety guards in place and the topper in the fully opened position it is safe to start topping.

- Begin to operate at a low RPM and gradually increase to 540 RPM before starting to move forward.

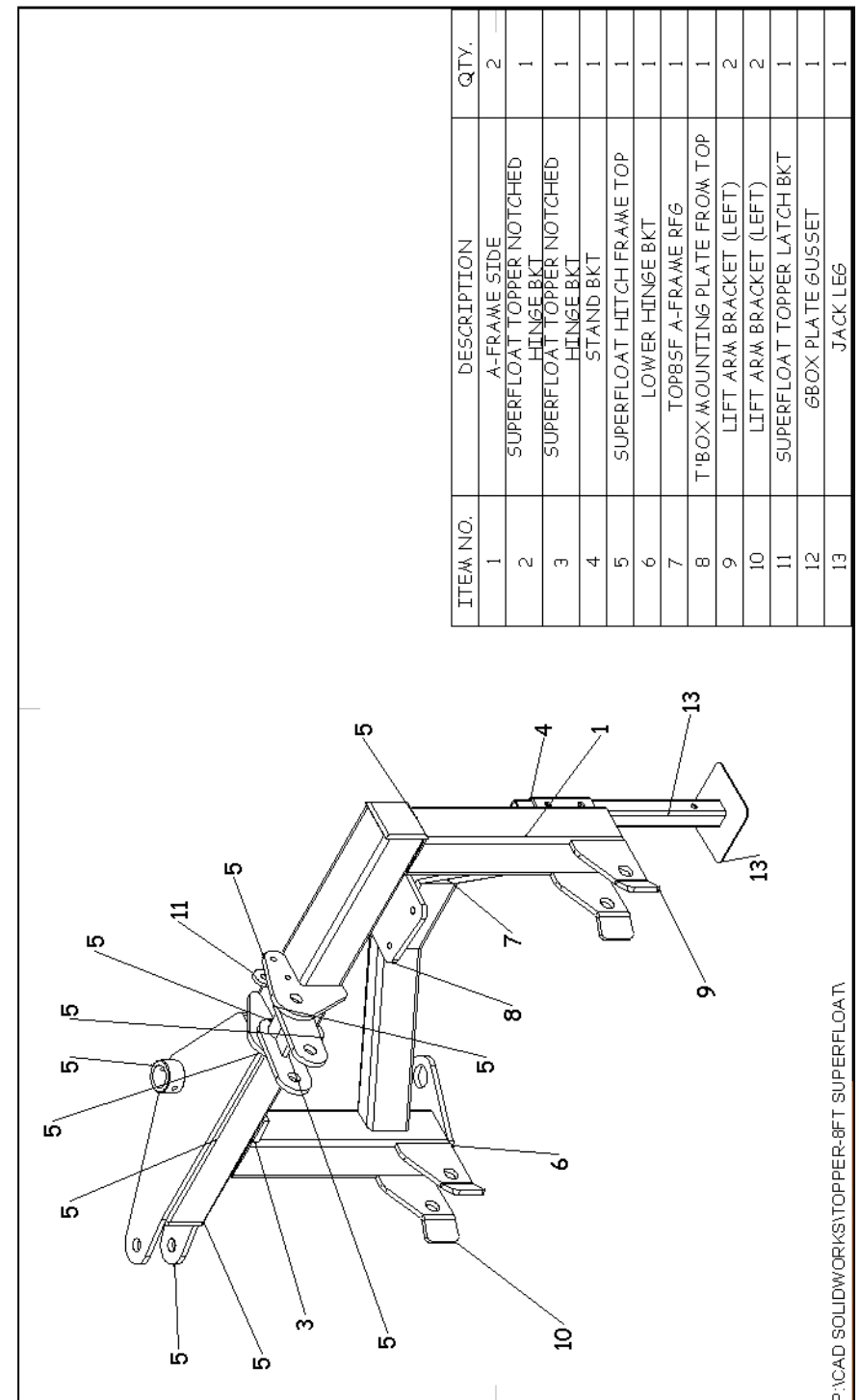

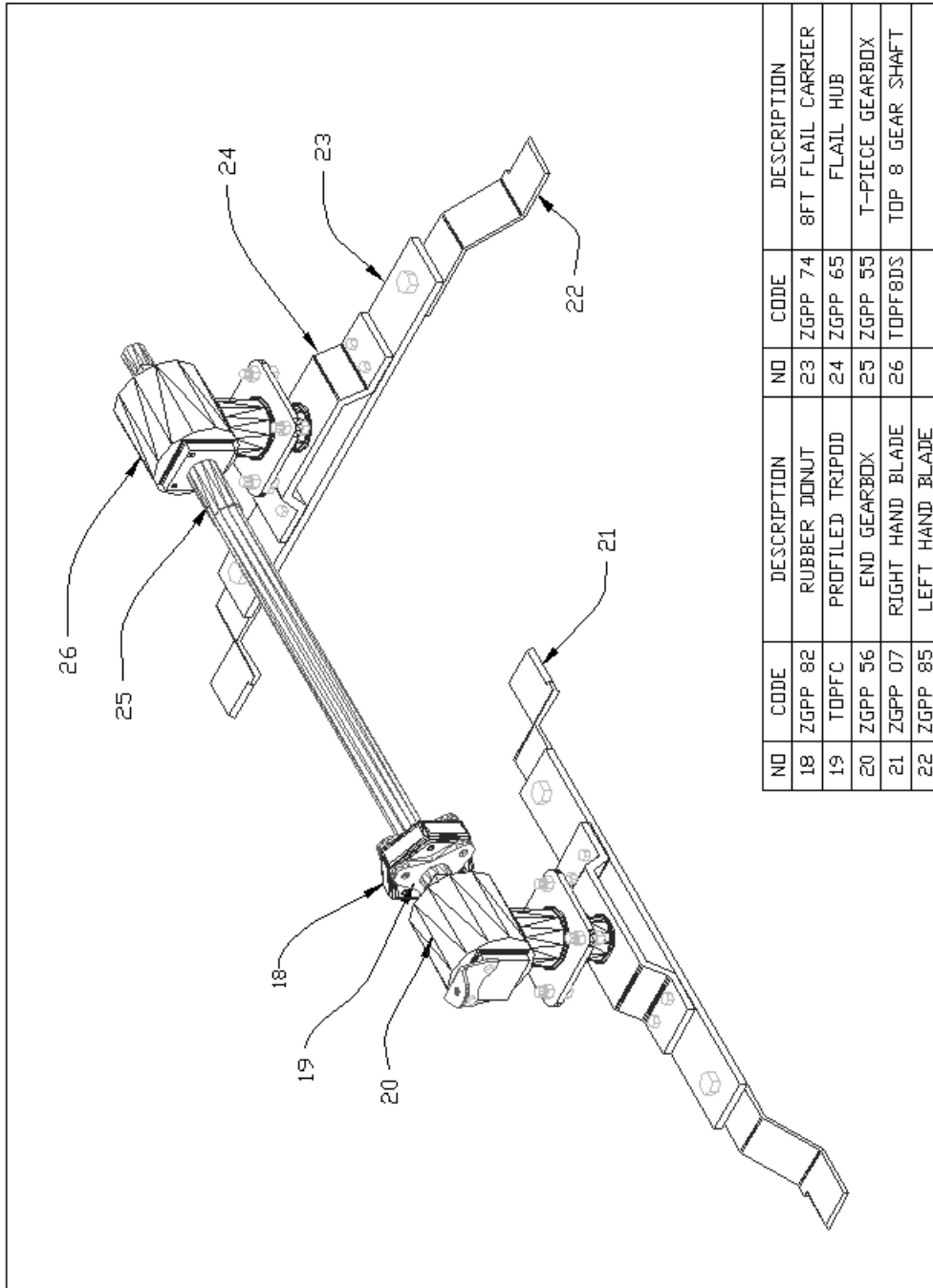

1.5 HYDRAULIC SAFETY

•**CAUTION** The hydraulic system is under high pressure.

•Ensure that only high-pressure hoses are used to connect supply to the toppers hydraulic cylinder. Check hoses regularly and renew any that are damaged or worn. **ALWAYS** ensure that hydraulic hoses are long enough to facilitate rotation of the topper body and are kept clear from the PTO shaft and 3 PL.

•Before working on the hydraulics lower the topper, ensure the locking mechanism is securely closed, release the pressure from the system and stop the tractor engine.

•When connecting hydraulic rams make sure that the hydraulic hoses are coupled correctly. Pressure should be released from the system both on the tractor and on the implement side prior to coupling the hoses to the tractor hydraulics.

•**CAUTION** Hydraulic oil forced out under pressure can break the skin and cause severe injury. In the event of a hydraulic oil leak stop the tractor flow immediately. **DO NOT PUT HANDS NEAR A LEAKING PIPE.**

ITEM	DESCRIPTION	QTY
1	M16 Locknut	4
2	Gearbox	1
3	M12 x 80 Bolt	6
4	Profiled Tripod	2
5	M12 Locknut	6
6	Rubber Doughnut	1
7	Drive Shaft	1
8	Main Chassis	1
9	M16 x 50 Bolt	4
10	M14 Locknut	4
11	Carrier Housing Bushing	1
12	M24 Locknut	2
13	Flail	2
14	M24 x 50 Bolt	2
15	M14 x 50 Bolt	4
16	Flail Carrier (750mm)	1

1.6 MAINTENANCE

- As a rule, disengage the driving system, apply the handbrake and stop the engine prior to carrying out maintenance, servicing, cleaning or repair work. **ALWAYS** remove the ignition key.
- Prop the topper with appropriate supports and ensure the blades have stopped moving before carrying out any maintenance.
- The manufacturer will not be responsible for any damages or injuries caused by unauthorised repair, alterations or mishandling of the product.
- Maintain product with care checking regularly for damage that would affect the safe operation of the implement.
- ALWAYS** use genuine Fleming parts.
- Check oil level in gearboxes before operating and at regular intervals
- Correct oil quantity is 0.8 litre in the rotor gearboxes and 1.2 litres in the L – gearbox. Change oil after first 50 hours and every 500 hours after.
- Use SAE 90 Gear Oil.
- Fill oil by removing plugs at top and side of gearbox.
- CAUTION** The gearboxes may become hot during use. Allow time for the housing and the oil to cool sufficiently before carrying any maintenance.
- To ensure that all the sludge's and contaminants are removed during an oil change, the oil should still be warm when it is drained.
- Grease PTO shaft tubes, universal joints and all other greasing points (marked with a sticker) daily.
- Check holding bolts on gearbox after every 5 hours of use and tighten if necessary for the first 20 hours and periodically afterwards.
- Regularly check that blades are kept sharp and free from damage. Replace if any damage is apparent.
- When replacing the blades ensure only the correct FLEMING blades are used (see figures for part numbers). Blades should be replaced in pairs to ensure that the rotor remains balanced. **ALWAYS** replace the blade bolts with new genuine Fleming bolts when the blades are changed.
- The bolts which attach the blades should be tightened fully and then slacked off until the blade is free to rotate.
- Coat the chrome area of the hydraulic cylinder with grease before any prolonged periods of inactivity
- ALWAYS** ensure all warning stickers are kept clean and in good condition replacing where necessary.
- CAUTION** paintwork may be damaged if high-powered washers are used when cleaning the topper.

