

8ft & 9ft WHEEL KIT LANDROLLER SPARE PARTS LIST

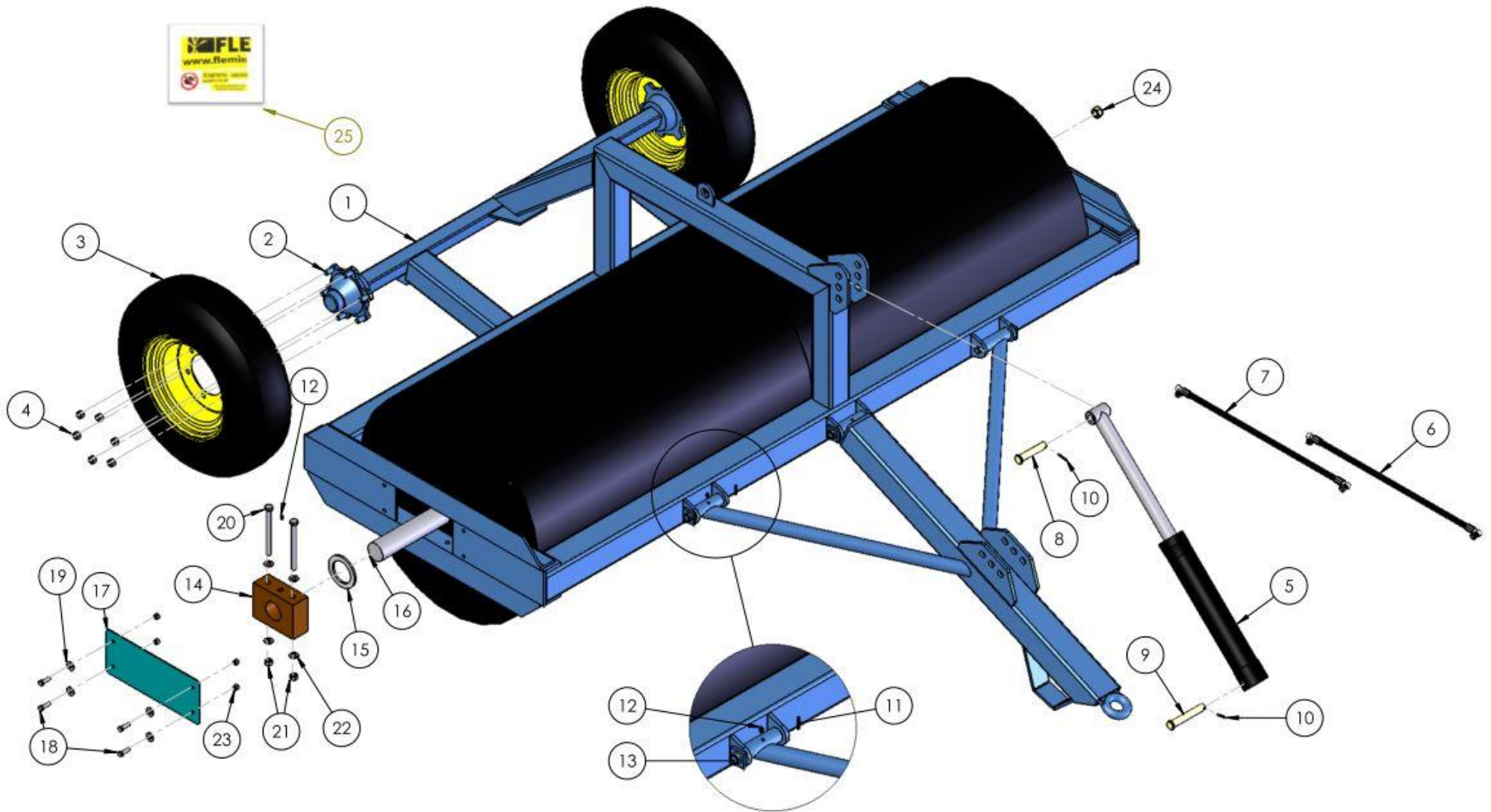

8ft & 9ft WHEEL KIT LANDROLLER ASSEMBLY



SEE TABLE NO: 001

TABLE NO: 001 WHEEL KIT LANDROLLER ASSEMBLY

ITEM NO	DESCRIPTION	8WK (8X36X12)		9WK (9X36X12)		9WK (9X36X16)	
		CODE	QTY	CODE	QTY	CODE	QTY
1	AXLE COMPLETE	ZGPP130	1	ZGPP130	1	ZGPP130	1
2	WHEEL STUD	AX18501.5	12	AX18501.5	12	AX18501.5	12
3	COMPLETE WHEEL	ZGPP68	2	ZGPP68	2	ZGPP68	2
4	WHEEL NUT	AX-181.5	12	AX-181.5	12	AX-181.5	12
5	HYDRAULIC RAM	ZGPP69	1	ZGPP69	1	ZGPP69	1
6	5' HYDRAULIC HOSE	ZGPP63	1	ZGPP63	1	ZGPP63	1
7	6' HYDRAULIC HOSE	ZGPP61	1	ZGPP61	1	ZGPP61	1
8	HYDRAULIC RAM PIN	ZGPP95	1	ZGPP95	1	ZGPP95	1
9	HYDRAULIC RAM PIN	ZGPP96	1	ZGPP96	1	ZGPP96	1
10	M6x40 ROLL PIN	ZFAS30	2	ZFAS30	2	ZFAS30	2
11	M8x70 ROLL PIN	ZFAS29	3	ZFAS29	3	ZFAS29	3
12	1/8" BSP GREASE NIPPLE	ZGPP30	5	ZGPP30	5	ZGPP30	5
13	WHEEL KIT DRAWBAR PIVOT PIN	P001.116	3	P001.116	3	P001.116	3
14	LANDROLLER BEARING	ZGPP53	2	ZGPP53	2	ZGPP53	2
15	SPACER / WASHER	ZPPA21	2	ZPPA21	2	ZPPA21	2
16	ROLLER SHAFT	P001.117	1	P001.118	1	P001.118	1
17	BEARING COVER PLATE	P001.119	2	P001.119	2	P001.119	2
18	M12x40 SETSCREW	ZFAS51	8	ZFAS51	8	ZFAS51	8
19	M12 WASHER ZP	ZFAS45	8	ZFAS45	8	ZFAS45	8
20	M16x200 BOLT	ZFAS17	4	ZFAS17	4	ZFAS17	4
21	M16 NYLOCK NUT	ZFAS23	4	ZFAS23	4	ZFAS23	4
22	M16 WASHER ZP	ZFAS36	8	ZFAS36	8	ZFAS36	8
23	M12 NYLOCK NUT	ZFAS22	8	ZFAS22	8	ZFAS22	8
24	1" BSP BUNG	ZFAS32	2	ZFAS32	2	ZFAS32	2
25	STICKER KIT	P001.529	1	P001.529	1	P001.529	1

WHEELKIT LANDROLLER BARRELL ASSEMBLY

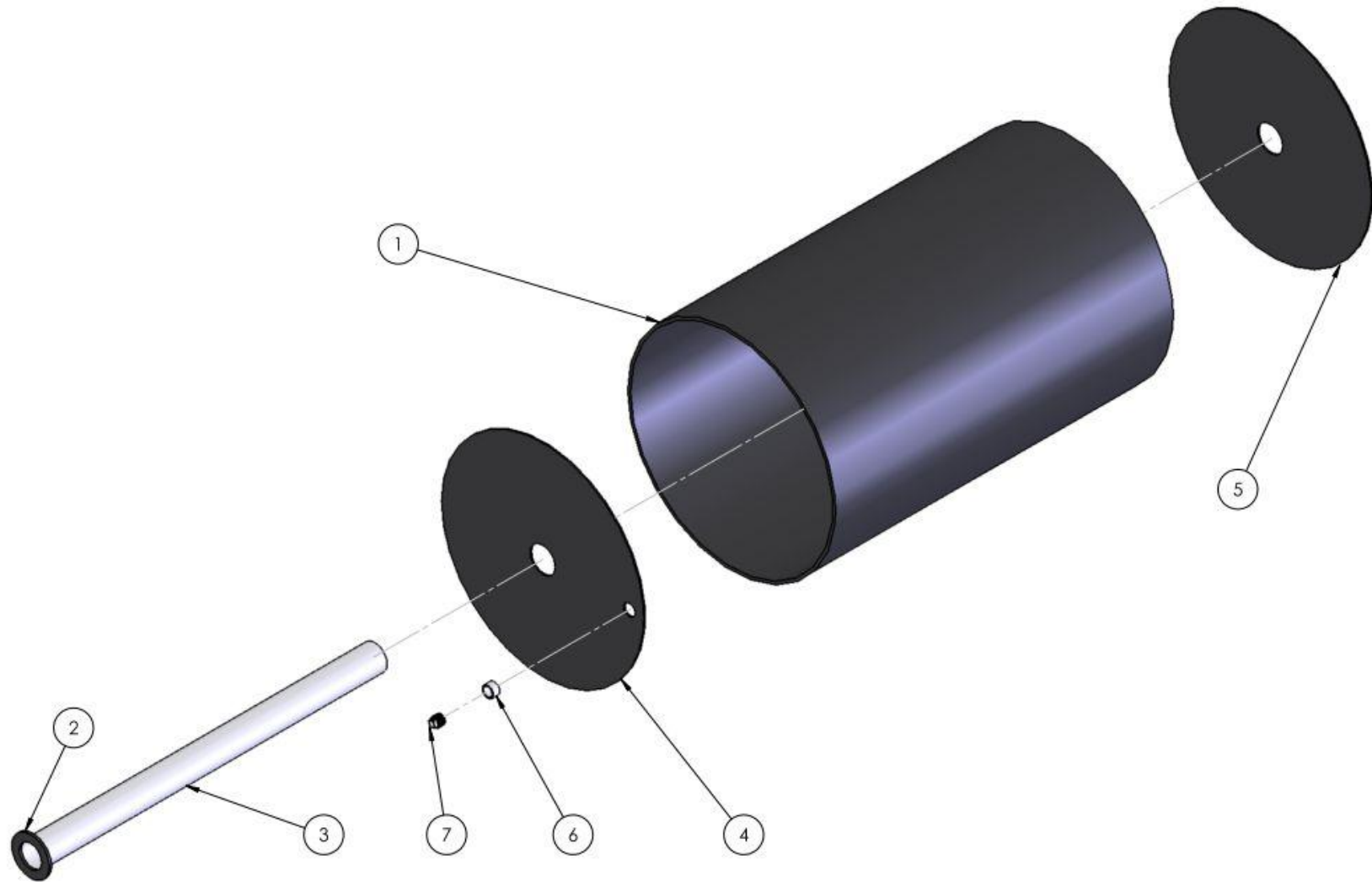

SEE TABLE NO: 002

TABLE NO: 002 WHEEL KIT LANDROLLER BARRELL ASSEMBLY

ITEM NO	DESCRIPTION	8WK (8X36X12)		9WK (9X36X12)		9WK (9X36X16)	
		CODE	QTY	CODE	QTY	CODE	QTY
1	COMPLETE BARRELL (ALL ITEMS)	P001.103	2	P001.107	2	P001.109	2
2	END WASHER	ZPPA21	2	ZPPA21	2	ZPPA21	2
3	CENTRE PIPE PLUS WASHER	P001.104	2	P001.108	2	P001.108	2
4	END DISC C/W DRAIN HOLE	ZPPA17A	2	ZPPA17A	2	ZPPA18A	2
5	END DISC	ZPPA17	2	ZPPA17	2	ZPPA18	2
6	1" SOCKET	ZFAS33	2	ZFAS33	2	ZFAS33	2
7	1" BUNG	ZFAS32	2	ZFAS32	2	ZFAS32	2

WHEELKIT ROLLER HYDRAULICS



SEE TABLE NO: 003

TABLE NO: 003 WHEEL KIT ROLLER HYDRAULICS			
ITEM NO	DESCRIPTION	3FT GRASS TOPPER	
		CODE	QTY
1	HYDRAULIC RAM	ZGPP69	1
2	5' HYDRAULIC HOSE	ZGPP63	1
3	6' HYDRAULIC HOSE	ZGPP61	1
4	½" DOWDY WASHER	ZHYD22	1
5	½" MALE PROBE	ZHYD26	1
6	HYDRAULIC RAM SEAL KIT	HYDSK9	1

WHEELKIT ROLLER AXLE PART No. ZGPP130

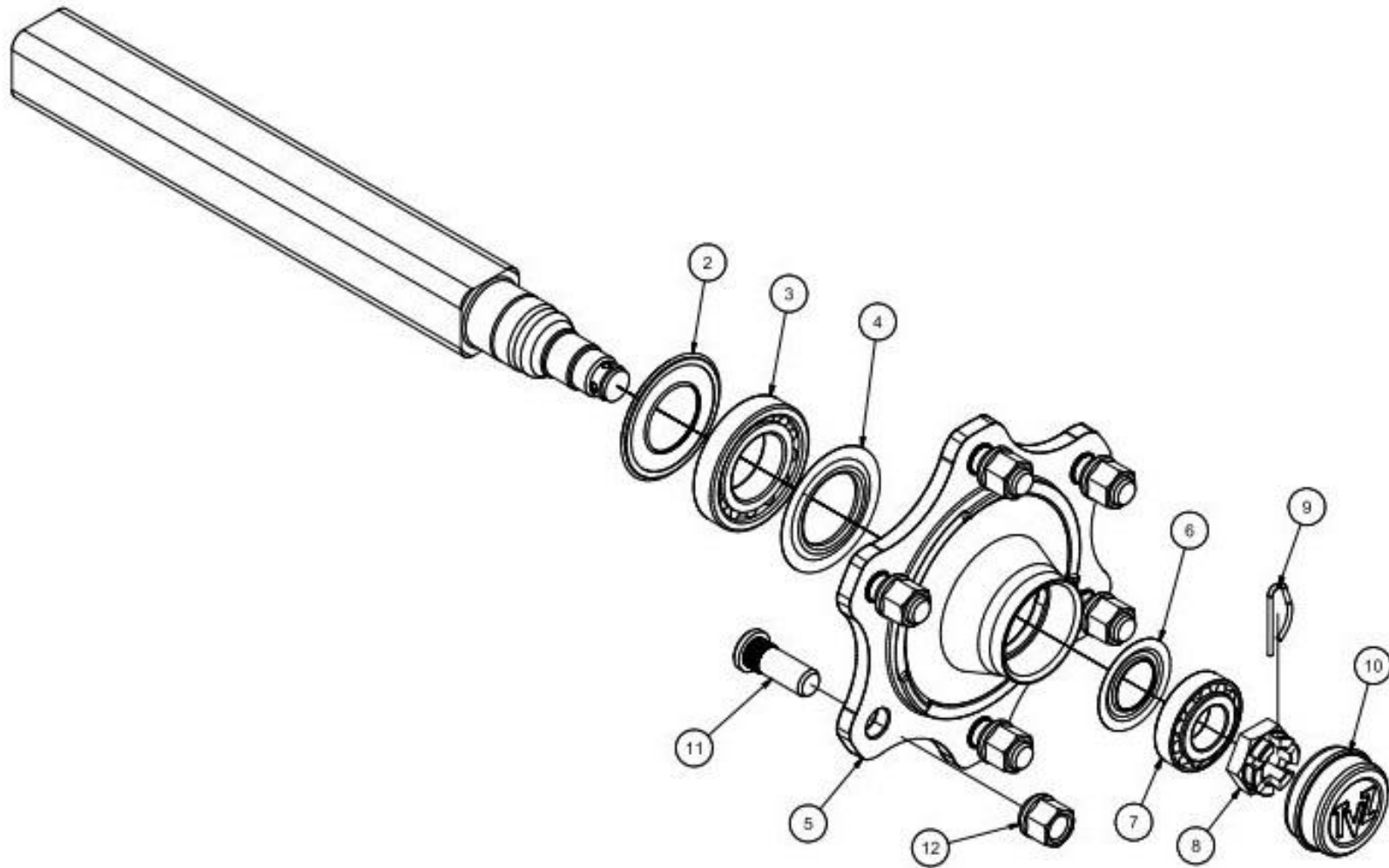

SEE TABLE NO: 004

TABLE NO: 004 WHEELKIT ROLLER TVZ AXLE**ZGPP130**

ITEM	PART NO.	QTY.	DESCRIPTION:
1	ZGPP130	1	AXLE COMPLETE
2	AX-5410851	2	REAR SEAL
3	AX-59130209	2	REAR BEARING
4	AX-5510851	2	INNER SEAL
5	AX-61L6JA002	2	HUB
6	AX-5510621	2	OUTER SEAL
7	AX-59130206	2	OUTER BEARING
8	AX-57527B1	2	CASTLE NUT
9	AX-58204	2	SPRING PIN
10	AX-56106210	2	DUST CAP
11	AX-18501.5	12	AXLE STUD 18mmx1.5mmx50mm
12	AX-181.5	12	AXLE NUT 18mmx1.5mm

