

STANDARD LANDROLLER SPARE PARTS LIST



Table of Contents:

STANDARD LANDROLLER SPARE PARTS LIST

8ft ROLLER MAIN ASSEMBLY	Page 4.
8ft ROLLER BARRELL ASSEMBLY	Page 6.
8ft ROLLER SCRAPER ASSEMBLY	Page 8.
8ft & 9ft LARGE BARRELL ROLLER MAIN ASSEMBLY	Page 11.
8ft & 9ft LARGE BARRELL ROLLER DRUM ASSEMBLY	Page 13.
8ft & 9ft LARGE BARRELL ROLLER SCRAPER ASSEMBLY	Page 15.
10ft ROLLER MAIN ASSEMBLY	Page 18.
10ft ROLLER DRUM ASSEMBLY	Page 20.
10ft ROLLER SCRAPER ASSEMBLY	Page 22.

8ft LANDROLLER SPARE PARTS LIST



8ft LANDROLLER MAIN ASSEMBLY

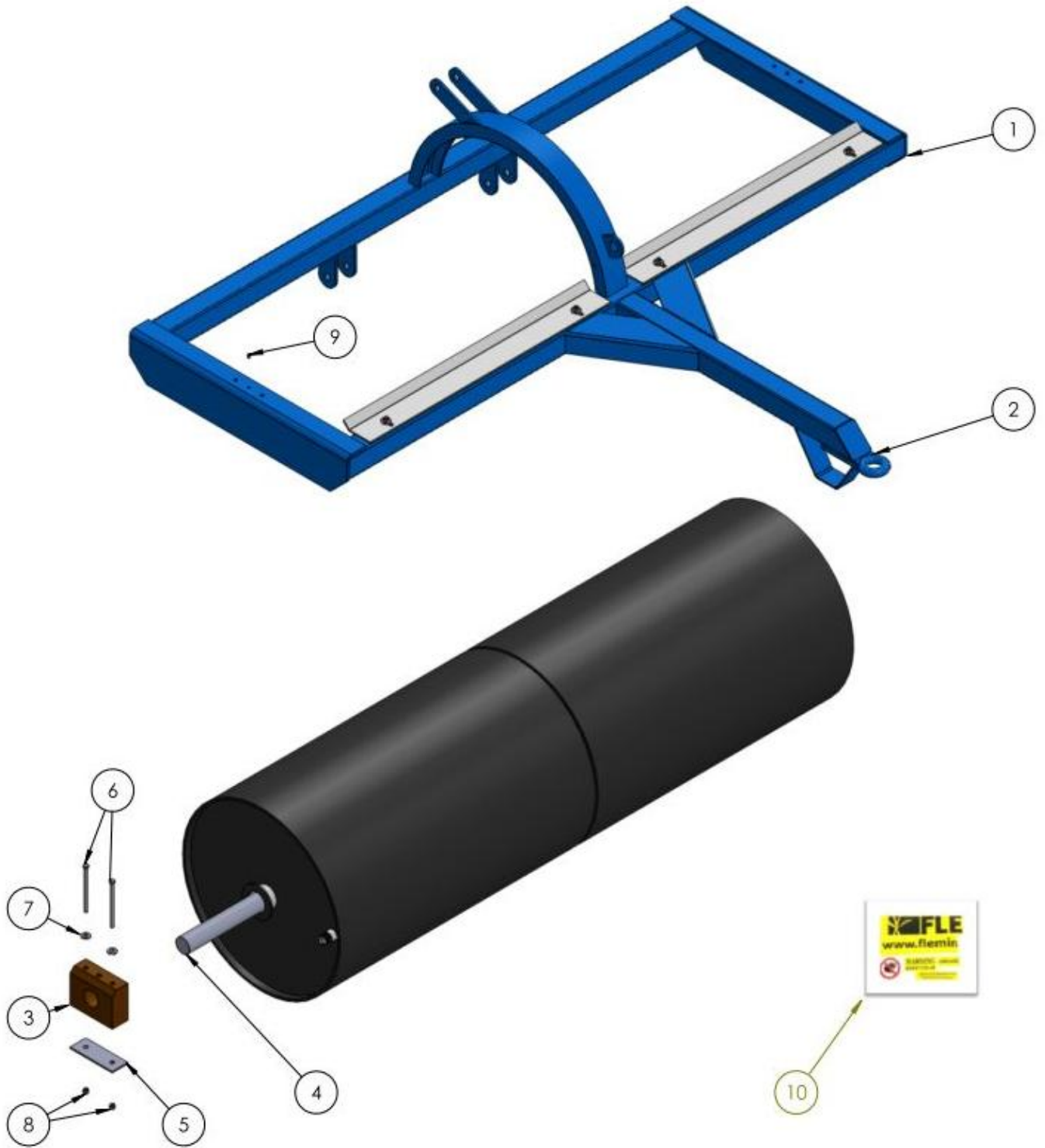

SEE TABLE NO: 001

TABLE NO: 001 8ft LANDROLLER MAIN ASSEMBLY

ITEM NO	DESCRIPTION	83010		83012	
		CODE	QTY	CODE	QTY
1	MAIN FRAME	P001.093	1	P001.093	1
2	TOWING EYE	ZGPP14	1	ZGPP14	1
3	LANDROLLER BEARING	ZGPP52	2	ZGPP52	2
4	LANDROLLER SHAFT	P001.094	1	P001.094	1
5	BEARING PLATE	ZGPP101	2	ZGPP101	2
6	BOLT	ZFAS16	4	ZFAS16	4
7	WASHER ZP	ZFAS45	4	ZFAS45	4
8	NYLOCK NUT	ZFAS22	4	ZFAS22	4
9	GREASE NIPPLE	ZGPP31	2	ZGPP31	4
10	STICKER KIT	P001.528	1	P001.528	1

8ft LANDROLLER DRUM ASSEMBLY

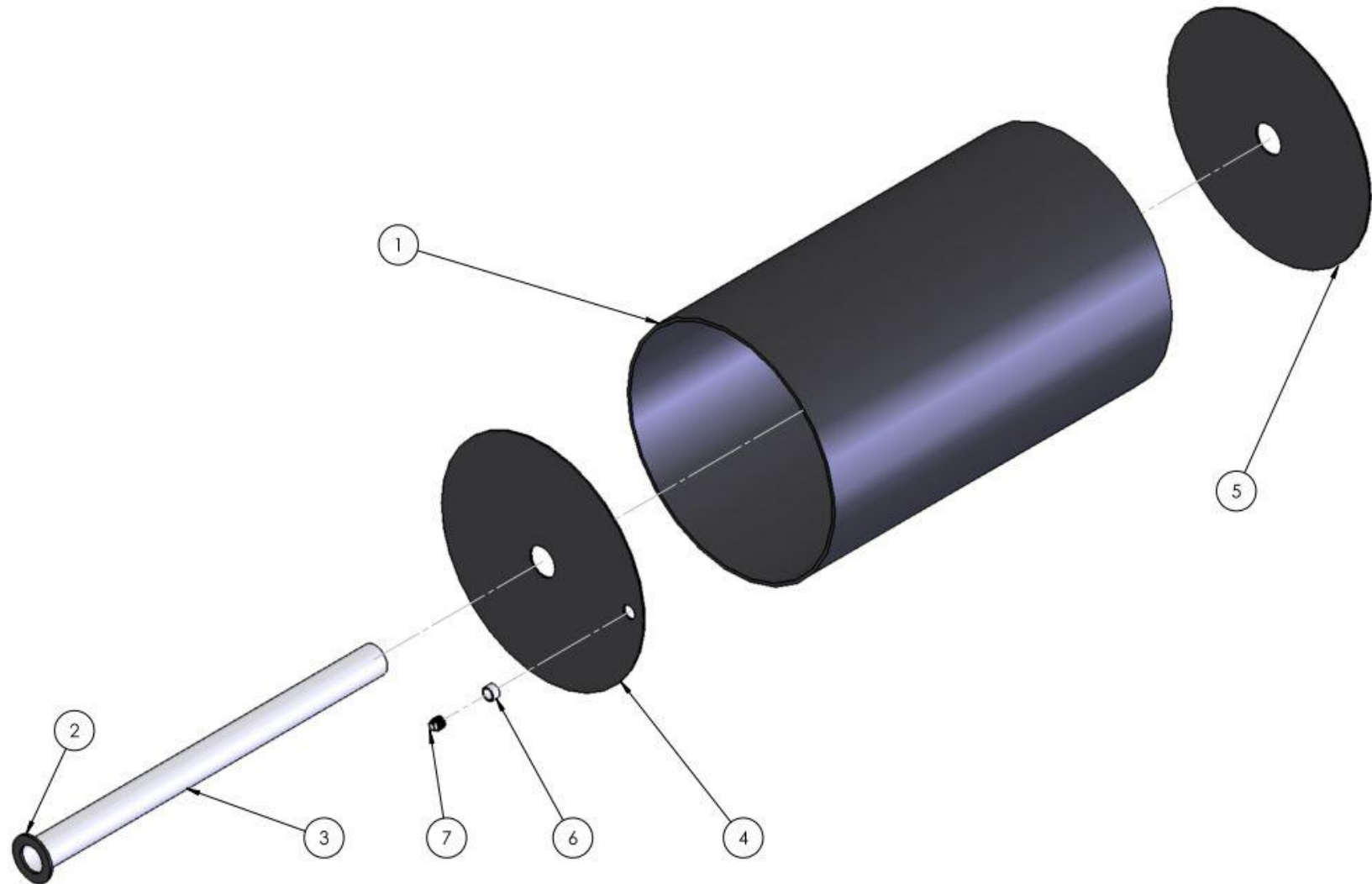

SEE TABLE NO: 002

TABLE NO: 002 8ft LANDROLLER BARRELL ASSEMBLY

ITEM NO	DESCRIPTION	83010		83012	
		CODE	QTY	CODE	QTY
1	COMPLETE BARRELL (ALL ITEMS)	P001.095	2	P001.096	2
2	END WASHER	ZPPA20A	2	ZPPA20A	2
3	CENTRE PIPE PLUS WASHER	P001.097	2	P001.097	2
4	END DISC C/W DRAIN HOLE	ZPPA15A	2	ZPPA16A	2
5	END DISC	ZPPA15	2	ZPPA16	2
6	1" SOCKET	ZFAS33	2	ZFAS33	2
7	1" BUNG	ZFAS32	2	ZFAS32	2

8ft LANDROLLER SCRAPER ASSEMBLY

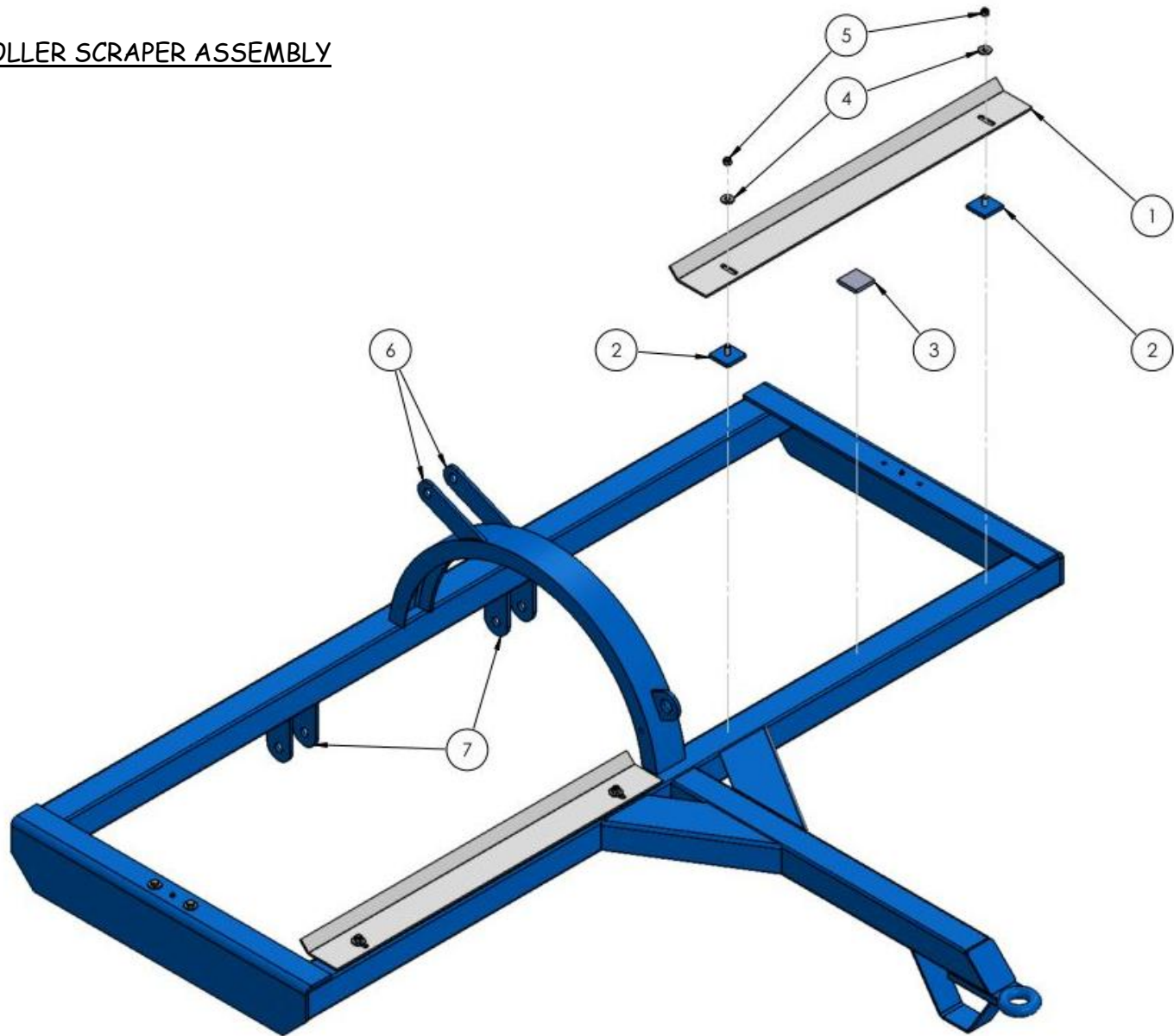

SEE TABLE NO: 003

TABLE NO: 003 8ft LANDROLLER SCRAPER ASSEMBLY

ITEM NO	DESCRIPTION	83010		83012	
		CODE	QTY	CODE	QTY
1	SCRAPER KIT (EXCLUDES ITEMS 2&3)	8SB	1	8SB	1
2	LOCATOR BRACKET (WELD ON)	P001.098	4	P001.098	4
3	SPACER BRACKET (WELD ON)	P001.099	2	P001.099	2
4	WASHER ZP	ZFAS45	4	ZFAS45	4
5	NYLOCK NUT	ZFAS22	4	ZFAS22	4
	COMPLETE BRACKET KIT (2 & 3)	P001.100	1	P001.100	1
6	TOPLINK BRACKET	ZPPA137	2	ZPPA137	2
7	LIFT ARM BRACKET	ZPPA133	4	ZPPA133	4

8ft & 9ft LARGE BARRELL LANDROLLER SPARE PARTS LIST



8ft & 9ft 36" BARRELL LANDROLLER MAIN ASSEMBLY

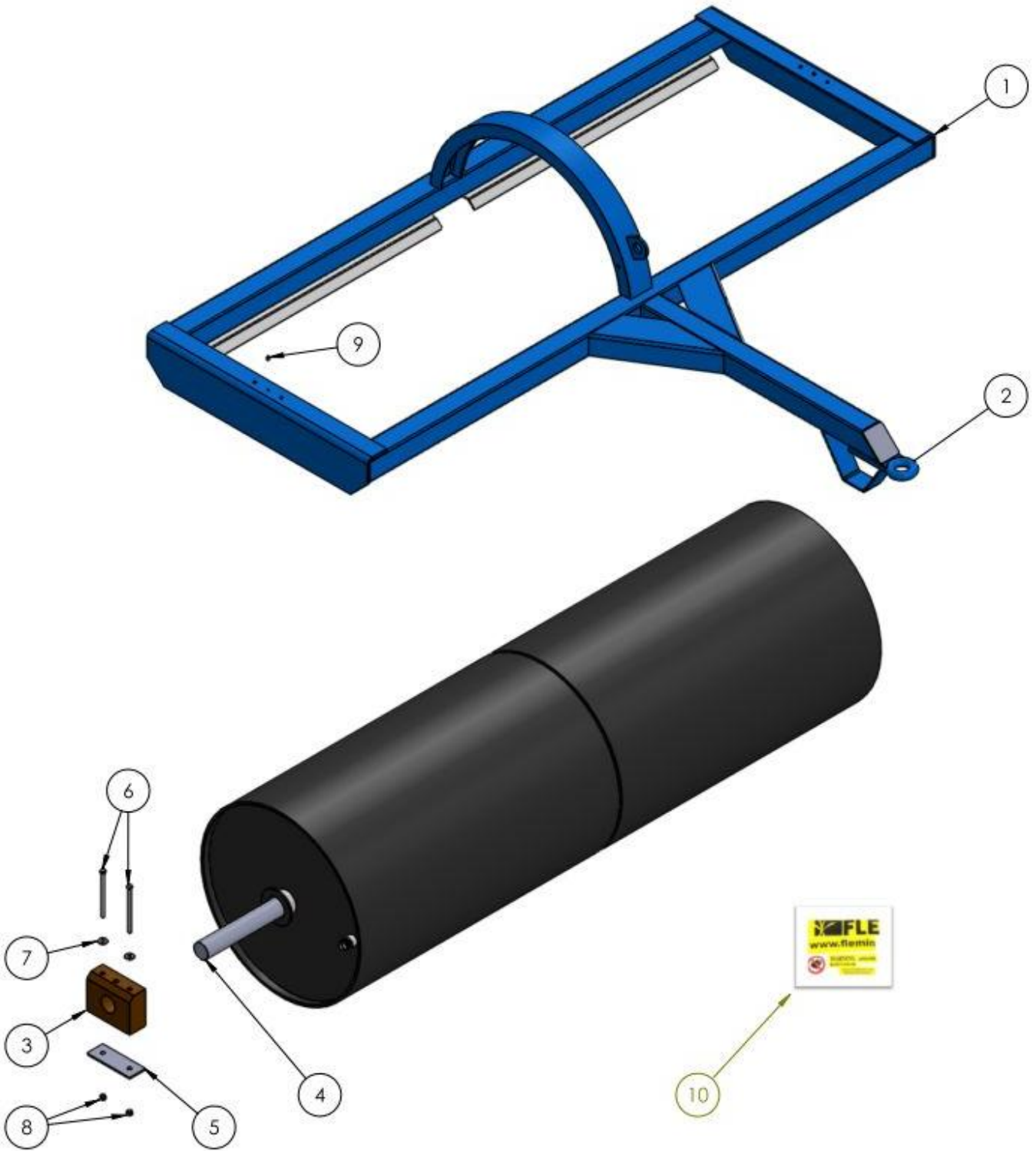

SEE TABLE NO: 004

TABLE NO: 004 8ft & 9ft LARGE BARRELL LANDROLLERS MAIN ASSEMBLY

ITEM NO	DESCRIPTION	83612		93612		93616	
		CODE	QTY	CODE	QTY	CODE	QTY
1	MAIN FRAME	P001.101	1	P001.105	1	P001.105	1
2	TOWING EYE	ZGPP14	1	ZGPP14	1	ZGPP14	1
3	LANDROLLER BEARING	ZGPP53	2	ZGPP53	2	ZGPP53	2
4	LANDROLLER SHAFT	P001.102	1	P001.106	1	P001.106	1
5	BEARING PLATE	ZGPP101A	2	ZGPP101A	2	ZGPP101A	2
6	BOLT	ZFAS17	4	ZFAS17	4	ZFAS17	4
7	WASHER ZP	ZFAS36	4	ZFAS36	4	ZFAS36	4
8	NYLOCK NUT	ZFAS23	4	ZFAS23	4	ZFAS23	4
9	GREASE NIPPLE	ZGPP31	2	ZGPP31	2	ZGPP31	2
10	STICKER KIT	P001.528	1	P001.528	1	P001.528	1

8ft & 9ft LARGE BARRELL LANDROLLER BARRELL ASSEMBLY

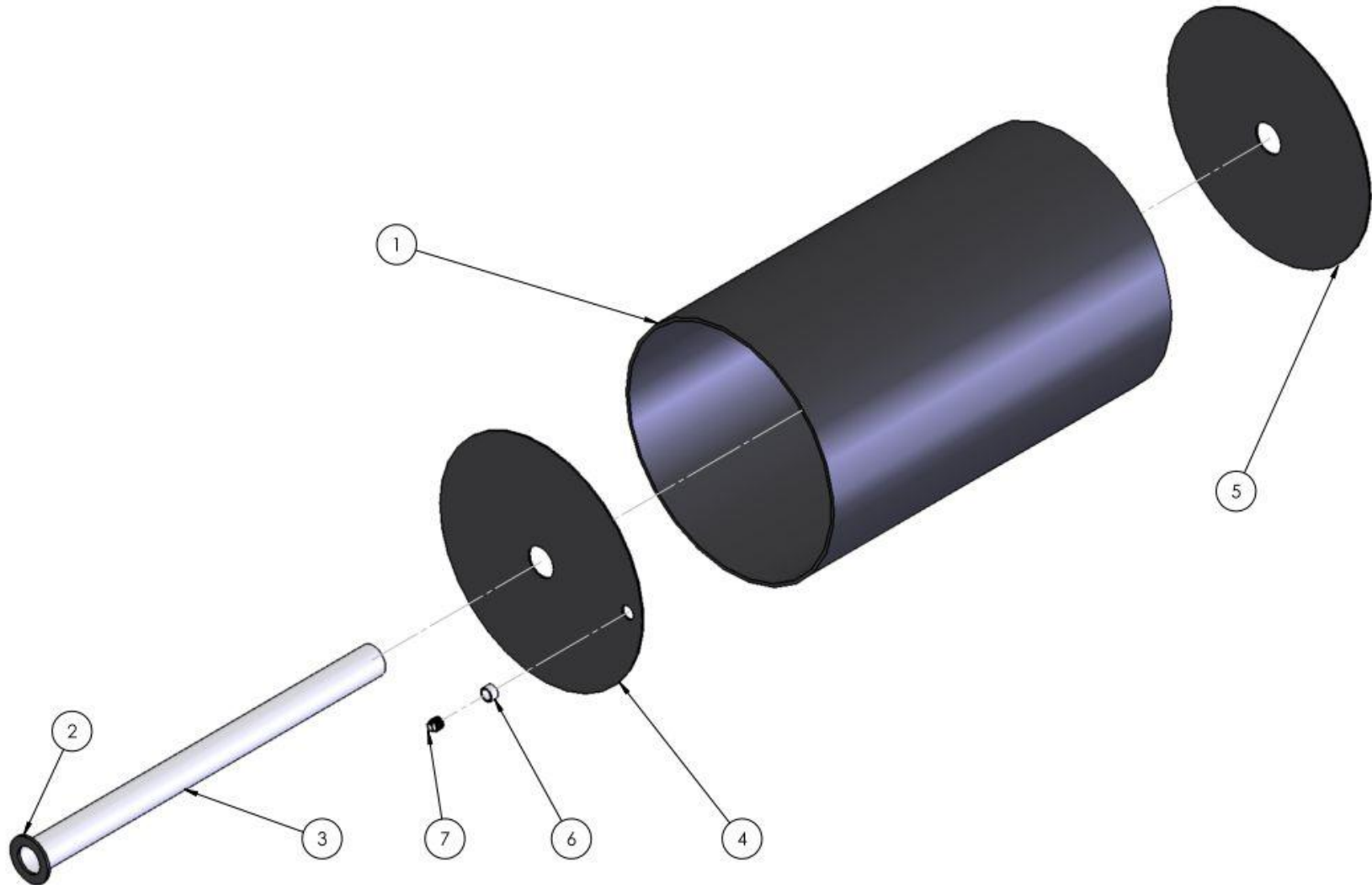

SEE TABLE NO: 005

TABLE NO: 005 8ft & 9ft LARGE BARRELL LANDROLLER BARRELL ASSEMBLY

ITEM NO	DESCRIPTION	83612		93612		93616	
		CODE	QTY	CODE	QTY	CODE	QTY
1	COMPLETE BARRELL (ALL ITEMS)	P001.103	2	P001.107	2	P001.109	2
2	END WASHER	ZPPA20	2	ZPPA20	2	ZPPA20	2
3	CENTRE PIPE PLUS WASHER	P001.104	2	P001.108	2	P001.108	2
4	END DISC C/W DRAIN HOLE	ZPPA17A	2	ZPPA17A	2	ZPPA18A	2
5	END DISC	ZPPA17	2	ZPPA17	2	ZPPA18	2
6	1" SOCKET	ZFAS33	2	ZFAS33	2	ZFAS33	2
7	1" BUNG	ZFAS32	2	ZFAS32	2	ZFAS32	2

8ft & 9ft LARGE BARRELL LANDROLLER SCRAPER ASSEMBLY

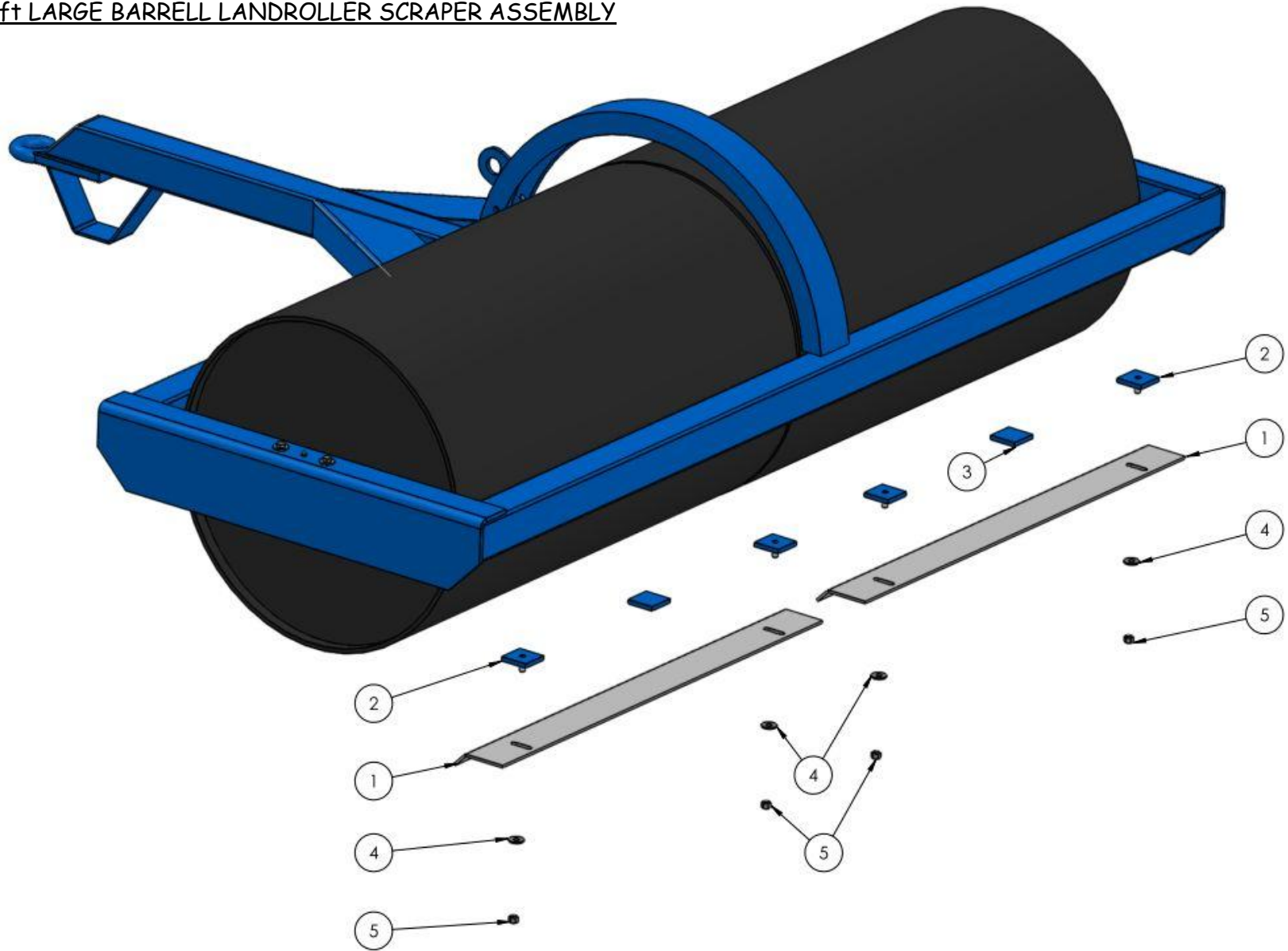

SEE TABLE NO: 006

TABLE NO: 006 8ft & 9ft LARGE BARRELL LANDROLLERS SCRAPER ASSEMBLY							
ITEM NO	DESCRIPTION	83612		93612		93616	
		CODE	QTY	CODE	QTY	CODE	QTY
1	SCRAPER KIT (EXCLUDES ITEMS 2&3)	8SB	1	9SB	1	9SB	1
2	LOCATOR BRACKET (WELD ON)	P001.098	4	P001.098	4	P001.098	4
3	SPACER BRACKET (WELD ON)	P001.099	2	P001.099	2	P001.099	2
4	WASHER ZP	ZFAS45	4	ZFAS45	4	ZFAS45	4
5	NYLOCK NUT	ZFAS22	4	ZFAS22	4	ZFAS22	4
	COMPLETE BRACKET KIT (2 & 3)	P001.100	1	P001.100	1	P001.100	1

10ft LANDROLLER SPARE PARTS LIST



10ft LANDROLLER MAIN ASSEMBLY

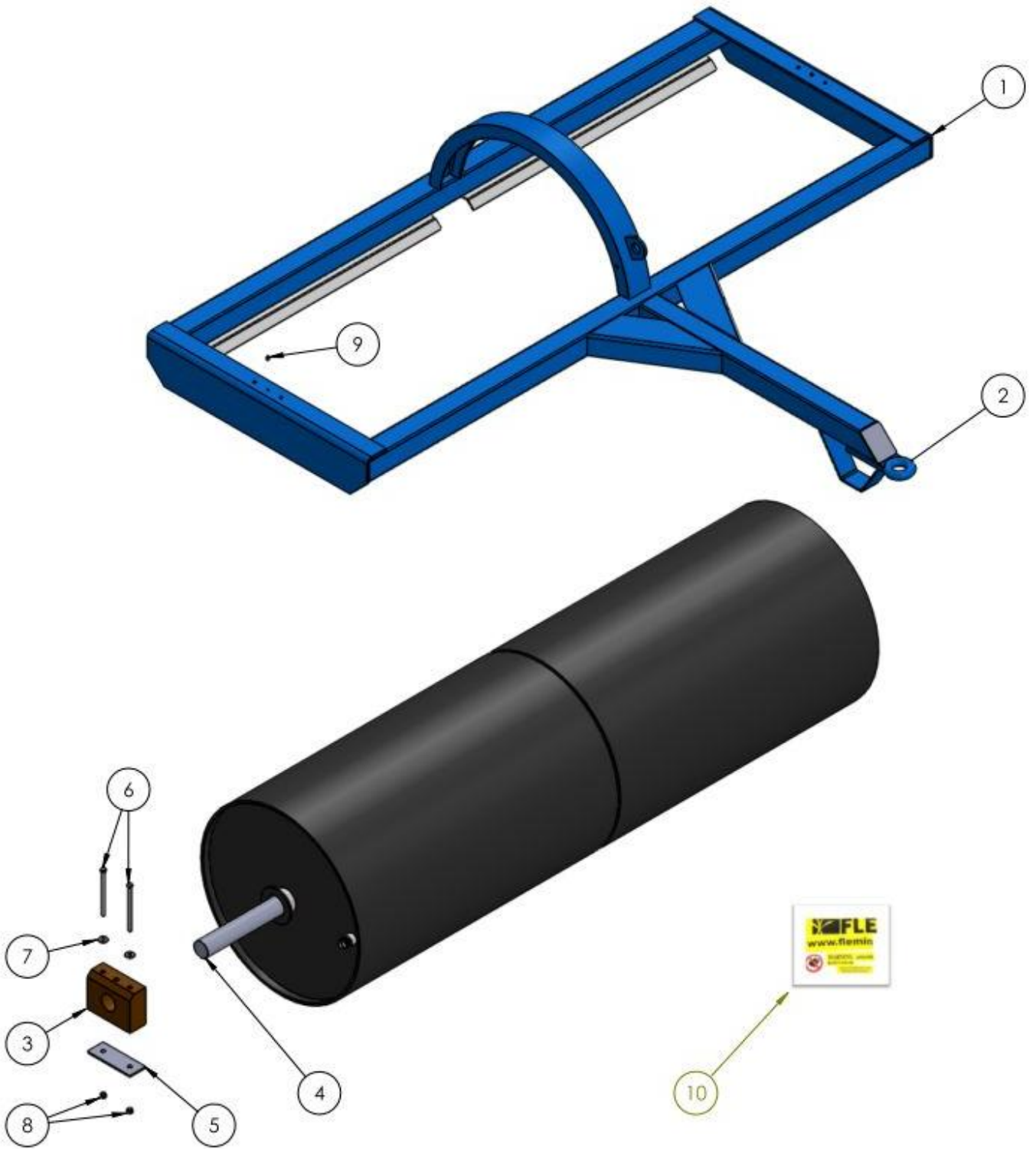

SEE TABLE NO: 007

TABLE NO: 007 10ft LANDROLLERS MAIN ASSEMBLY

ITEM NO	DESCRIPTION	103010		103612		103016	
		CODE	QTY	CODE	QTY	CODE	QTY
1	MAIN FRAME	P001.133	1	P001.110	1	P001.114	1
2	TOWING EYE	ZGPP14	1	ZGPP14	1	ZGPP14	1
3	LANDROLLER BEARING	ZGPP53	2	ZGPP53	2	ZGPP53	2
4	LANDROLLER SHAFT	P001.111	1	P001.111	1	P001.111	1
5	BEARING PLATE	ZGPP101A	2	ZGPP101A	2	ZGPP101A	2
6	BOLT	ZFAS17	4	ZFAS17	4	ZFAS17	4
7	WASHER ZP	ZFAS36	4	ZFAS36	4	ZFAS36	4
8	NYLOCK NUT	ZFAS23	4	ZFAS23	4	ZFAS23	4
9	GREASE NIPPLE	ZGPP31	2	ZGPP31	2	ZGPP31	2
10	STICKER KIT	P001.528	1	P001.528	1	P001.528	1

10ft LANDROLLER DRUM ASSEMBLY

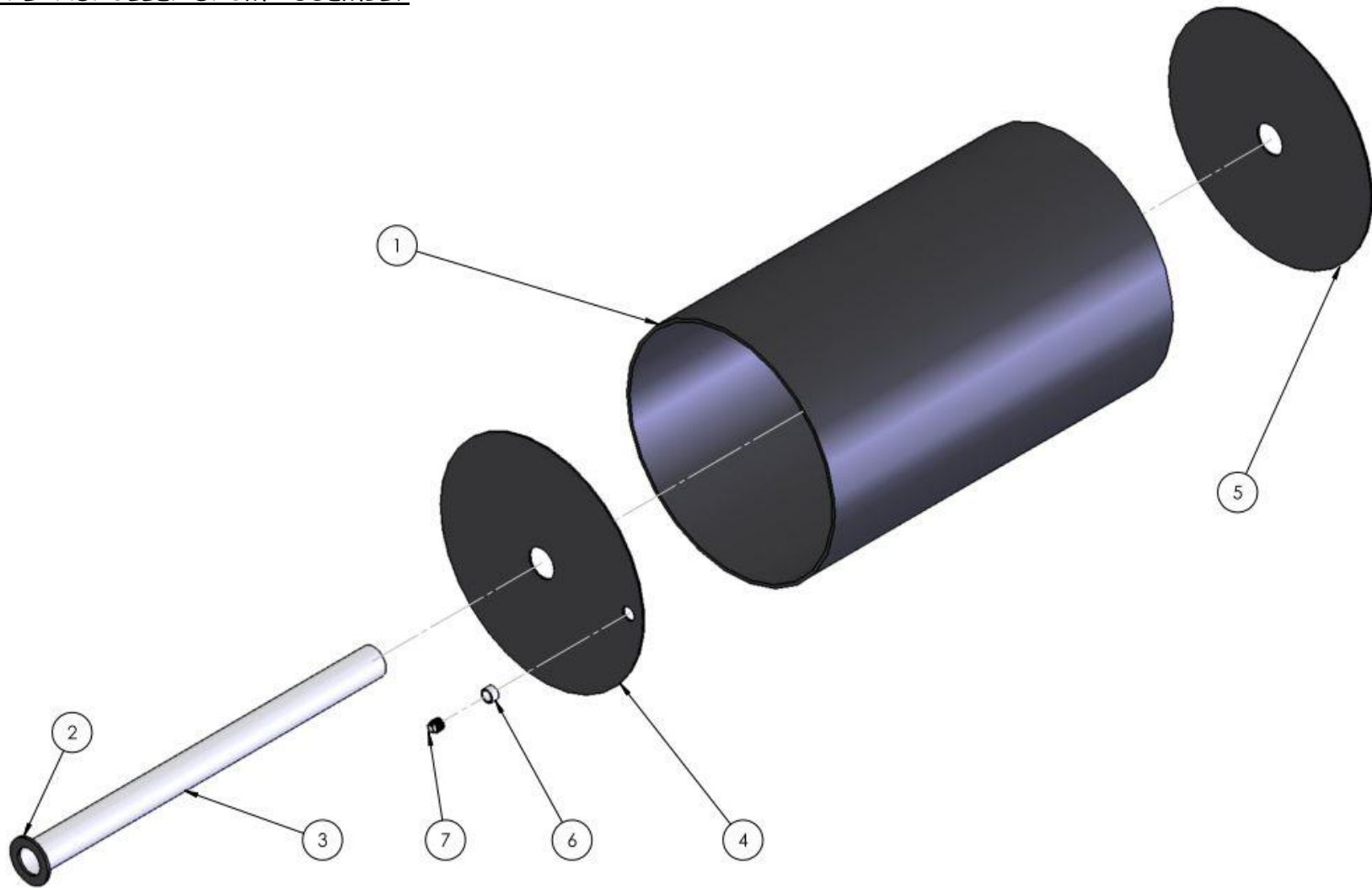

SEE TABLE NO: 008

TABLE NO: 008 10ft LANDROLLER BARRELL ASSEMBLY

ITEM NO	DESCRIPTION	103010		103612		103016	
		CODE	QTY	CODE	QTY	CODE	QTY
1	COMPLETE BARRELL (ALL ITEMS)	P001.134	2	P001.112	2	P001.115	2
2	END WASHER	ZPPA20	2	ZPPA20	2	ZPPA20	2
3	CENTRE PIPE PLUS WASHER	P001.113	2	P001.113	2	P001.113	2
4	END DISC C/W DRAIN HOLE	ZPPA199A	2	ZPPA320A	2	ZPPA119A	2
5	END DISC	ZPPA199	2	ZPPA320	2	ZPPA119	2
6	1" SOCKET	ZFAS33	2	ZFAS33	2	ZFAS33	2
7	1" BUNG	ZFAS32	2	ZFAS32	2	ZFAS32	2

10ft LANDROLLER SCRAPER ASSEMBLY

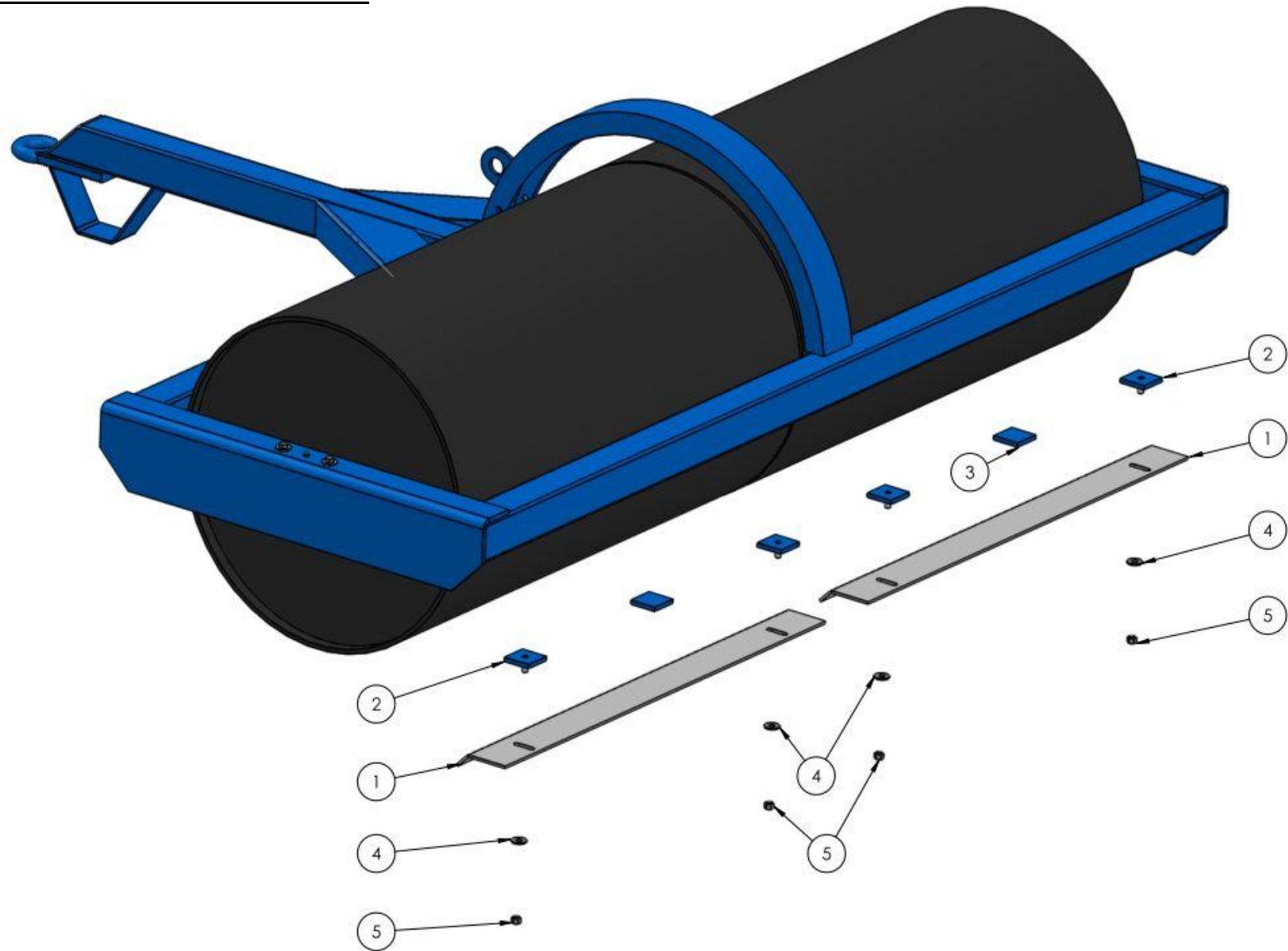

SEE TABLE NO: 009

TABLE NO: 009 10ft LANDROLLERS SCRAPER ASSEMBLY

ITEM NO	DESCRIPTION	103010		103612		103016	
		CODE	QTY	CODE	QTY	CODE	QTY
1	SCRAPER KIT (EXCLUDES ITEMS 2&3)	10SB	1	10SB	1	10SB	1
2	LOCATOR BRACKET (WELD ON)	P001.098	4	P001.098	4	P001.098	4
3	SPACER BRACKET (WELD ON)	P001.099	2	P001.099	2	P001.099	2
4	WASHER ZP	ZFAS45	4	ZFAS45	4	ZFAS45	4
5	NYLOCK NUT	ZFAS22	4	ZFAS22	4	ZFAS22	4
	COMPLETE BRACKET KIT (2 & 3)	P001.100	1	P001.100	1	P001.100	1