

AGRICULTURAL MACHINERY

sitrex®
Spa

ASSEMBLY, USE AND MAINTENANCE SPARE PARTS LIST

RT/5200 – RT/5200-H 3RD POINT HITCH

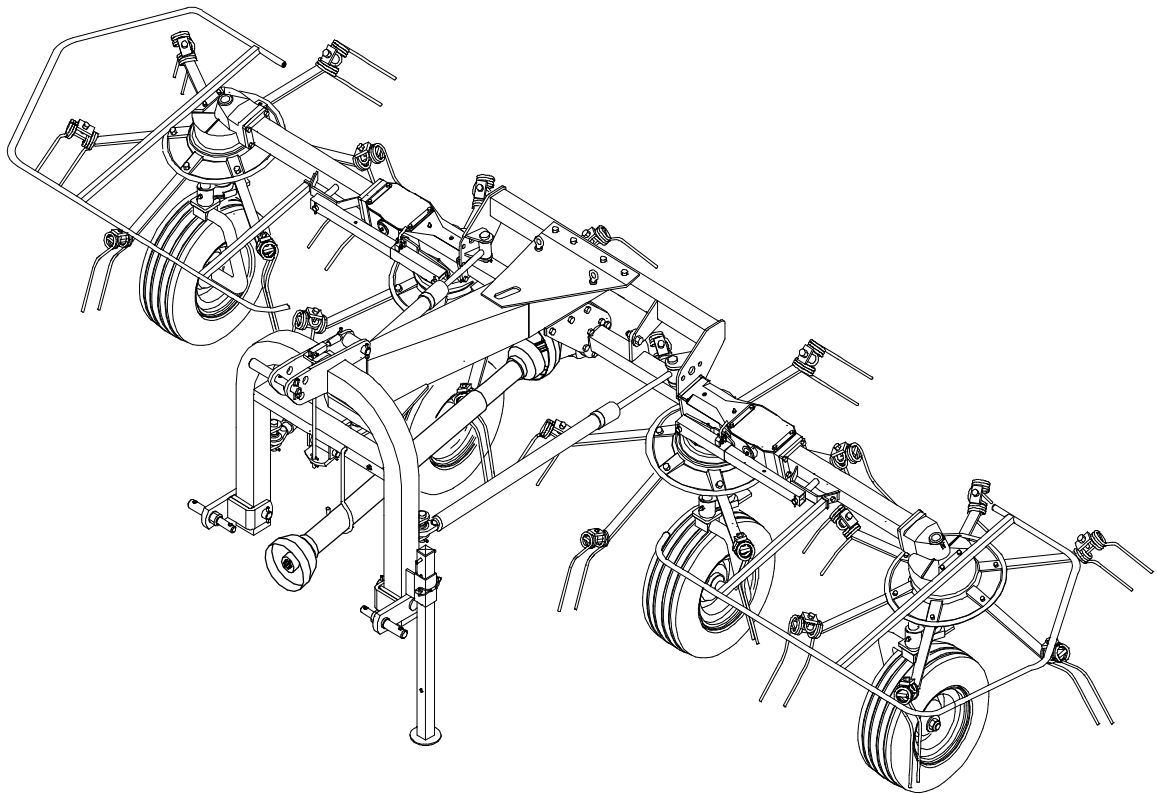

ROTARY TEDDER

04/15

SPARE PARTS LIST

FOR CORRECT SPARE PARTS ORDER IT IS NECESSARY TO SPECIFY:
TABLE NUMBER, ITEM, PART NO, DESCRIPTION AND QUANTITY OF
PARTS REQUIRED.

ITEMS DESCRIBED AS RH AND LH ARE MEANT FACING REAR OF
MACHINE.

TABLE 920.222/a

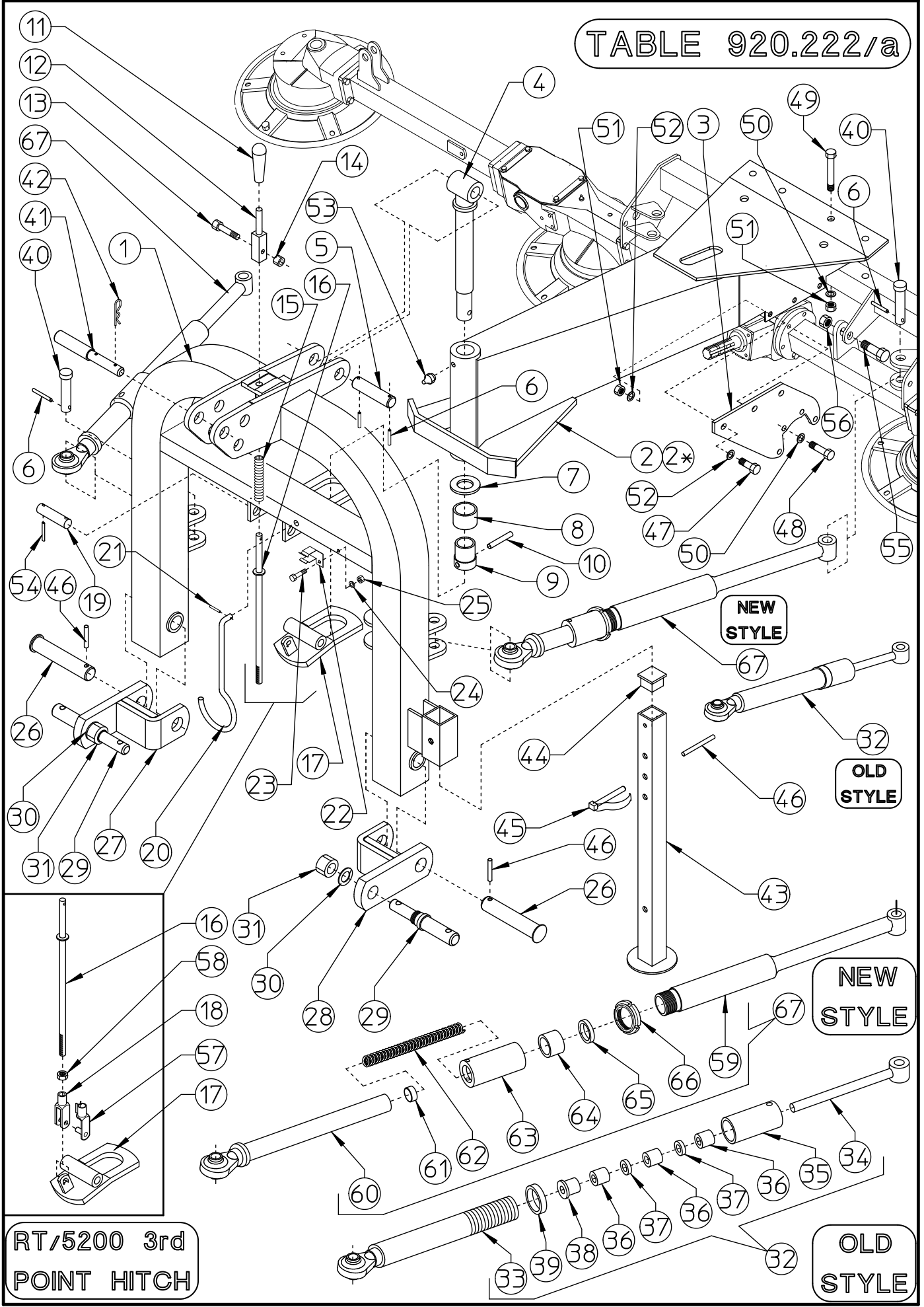

RT/5200 3rd POINT HITCH - TABLE PART NO 920.222/a (HYDRAULIC AND SPRING LIFT VERSION)

ITEM	Q.ty	PART NO	DESCRIPTION	NOTE
1	1	220.990	3rd POINT HITCH	SPRING LIFT VERSION
2	1	220.991	DRAWBAR	HYDRAULIC LIFT VERSION
2*	1	230.017	DRAWBAR	
3	2	230.016	SUPPORT	
4	1	220.053	PIN	
5	1	210.560	PIN	
6	6	600.538	SPRING PIN (ø6x35)	
7	1	210.530	SHIM	
8	1	220.237	BUSH	
9	1	220.055	BUSH	
10	1	600.584	SPRING PIN (ø10x50)	
11	1	600.830	HANDLE	
12	1	220.252	LEVER	
13	1	610.191	SCREW (M6x30-5737)	
14	1	600.472	NUT (M6-DIN980)	
15	1	200.374	SPRING	
16	1	220.995	TIE ROD	
17	1	230.034	RATCHET	
18	1	620.370	FORK M12	
19	1	220.054	PIN	
20	1	200.991	CARDAN SUPPORT	
21	1	600.841	SPRING PIN (ø3,5x18)	
22	1	200.992	CLIP	
23	1	600.833	SCREW (M4x16-6107)	
24	1	600.839	SPRING WASHER (ø4,5-8842)	
25	1	600.836	NUT (M4-5588)	
26	2	210.483	PIN	
27	1	220.684	RH LOWER LINK	
28	1	220.683	LH LOWER LINK	
29	2	210.813	PIN	
30	2	600.246	SPRING WASHER (ø25-1751)	
31	2	600.244	NUT (M24x2-5588)	
32	2	220.998	SHOCK ABSORBER ASSY	OLD STYLE
33	2	220.999	SHOCK ABSORBER BODY	OLD STYLE
34	2	230.035	ROD	OLD STYLE

TABLE 920.222/a

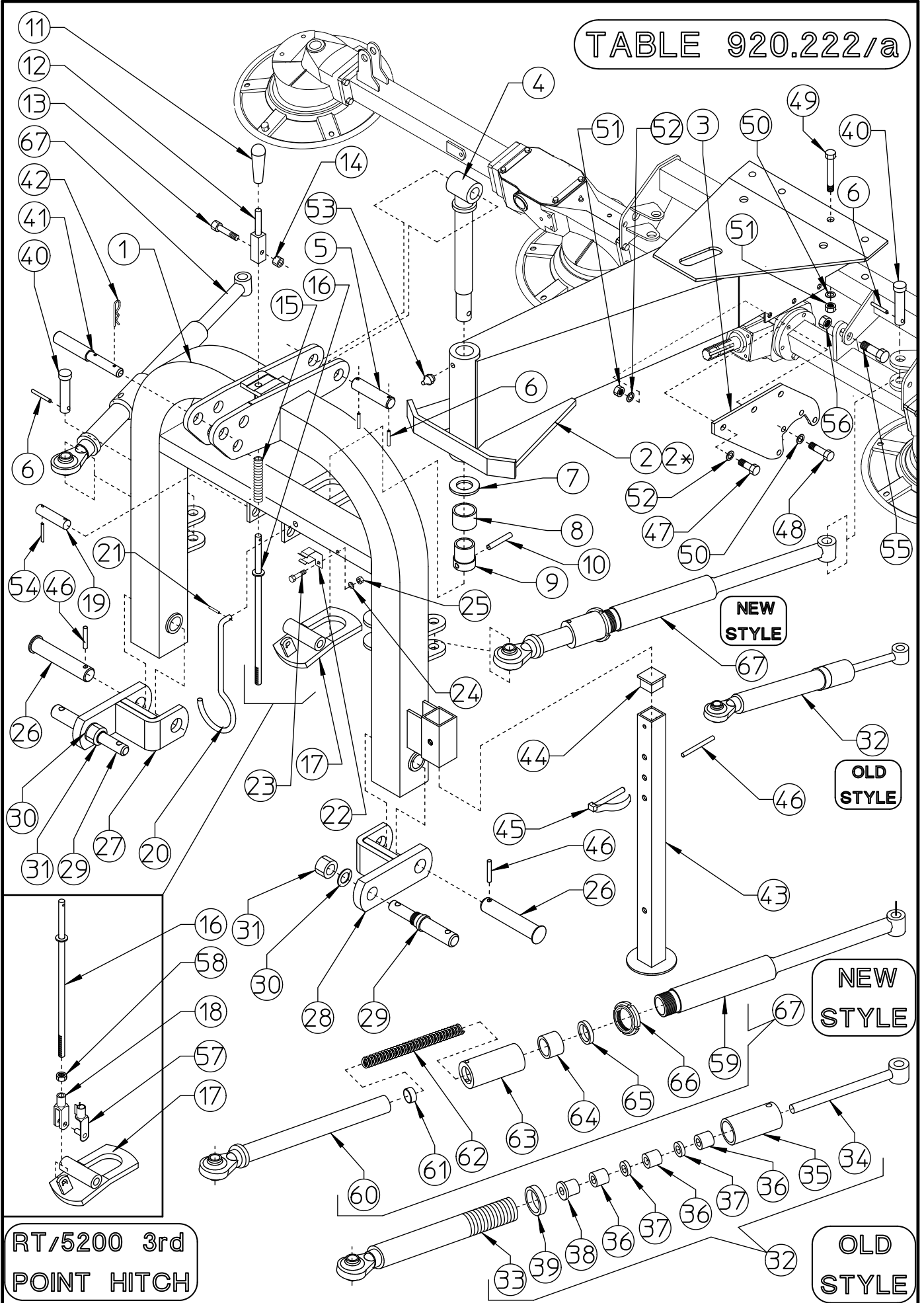

RT/5200 3rd POINT HITCH - TABLE PART NO 920.222/a (HYDRAULIC AND SPRING LIFT VERSION)

ITEM	Q.ty	PART NO	DESCRIPTION	NOTE
35	2	210.647	BUSH	OLD STYLE
36	6	210.653	RUBBER BUSH	OLD STYLE
37	4	210.648	SHIM	OLD STYLE
38	2	210.649	BUSH	OLD STYLE
39	2	610.337	SELF LOCKING NUT (M40x1,5)	OLD STYLE
40	4	220.996	PIN	
41	1	200.343	PIN	
42	1	600.308	CLIP (BC4)	
43	1	210.482	JACK STAND	
44	1	600.817	PLUG	
45	1	600.842	PIN (ø10/70)	
46	3	600.027	SPRING PIN (ø8x50)	
47	6	600.616	SCREW (M12x35-5739)	
48	8	600.687	SCREW (M12x45-5737)	
49	4	600.390	SCREW (M12x80-5737)	
50	12	600.018	SPRING WASHER (ø13-1751)	
51	10	600.077	NUT (M12-DIN980)	
52	12	600.089	WASHER (ø13-6592)	
53	1	600.124	GREASE NIPPLE (M6)	
54	2	600.108	SPRING PIN (ø8x40)	
55	2	610.497	SCREW (M20x50-5739)	
56	2	600.717	NUT (M20-DIN980)	
57	1	620.371	CLIP	
58	1	600.132	NUT (M12-5589)	
59	2	250.374	REAR TUBE ABSORBER	NEW STYLE (FROM 04-2015)
60	2	230.477	FRONT TUBE ABSORBER	NEW STYLE (FROM 04-2015)
61	2	250.378	SHIM ø27x15	NEW STYLE (FROM 04-2015)
62	2	210.432	SPRING	NEW STYLE (FROM 04-2015)
63	2	230.882	HEAD ABSORBER	NEW STYLE (FROM 04-2015)
64	2	230.881	RUBBER BUSH	NEW STYLE (FROM 04-2015)
65	2	230.883	SHIM ø35-50x5	NEW STYLE (FROM 04-2015)
66	2	630.826	NUT M55x2	NEW STYLE (FROM 04-2015)
67	2	250.373	SHOCK ABSORBER ASSY	NEW STYLE (FROM 04-2015)

TABLE 920.224

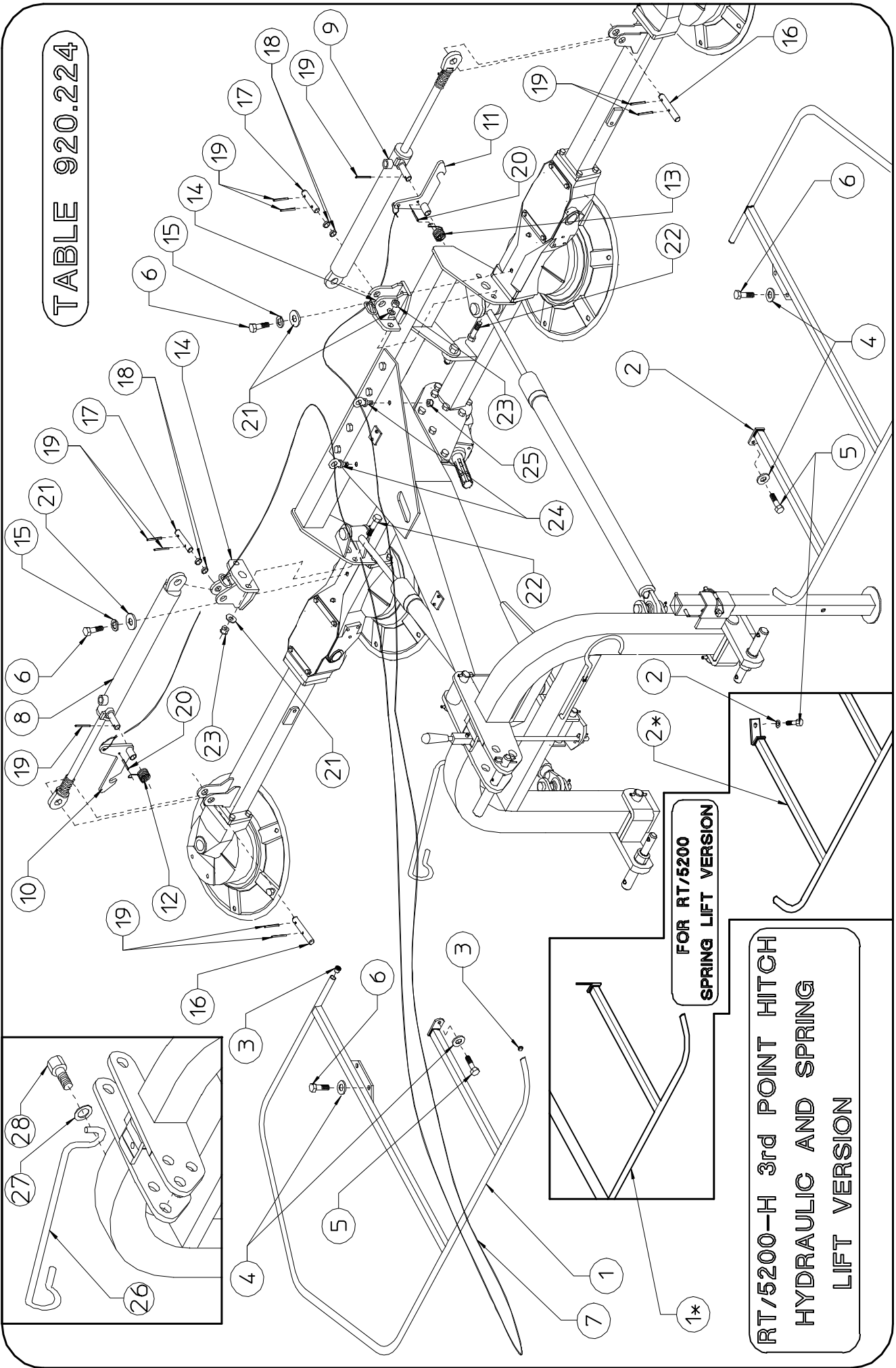

RT/5200-H-TABLE PART NO 920.224 (HYDRAULIC AND SPRING LIFT VERSION)

ITEM	Q.ty	PART NO	DESCRIPTION	NOTE
1	1	210.074	RH LATERAL GUARD	HYDRAULIC LIFT VERSION
1*	1	210.076	RH LATERAL GUARD	SPRING LIFT VERSION
2	1	210.075	LH LATERAL GUARD	HYDRAULIC LIFT VERSION
2*	1	210.077	LH LATERAL GUARD	SPRING LIFT VERSION
3	4	600.854	PLUG	
4	6	600.634	SPRING WASHER (ø13-ZN)	
5	2	600.770	SCREW (M12x20 5739-ZN)	
6	6	600.441	SCREW (M12x25 5739-ZN)	
7	1	210.009	ROPE	
8	1	220.822	RH CYLINDER	
9	1	220.823	LH CYLINDER	
10	1	210.098	RH COUPLER	
11	1	210.099	LH COUPLER	
12	1	210.093	RH SPRING	
13	1	210.094	LH SPRING	
14	2	220.825	HITCH	
15	2	600.018	SPRING WASHER (ø13-ZN)	
16	2	210.103	PIN	
17	2	220.828	PIN	
18	4	230.018	SHIM	
19	10	600.538	SPRING PIN (ø6x35)	
20	2	600.773	SPRING PIN (ø6x30)	
21	6	600.089	WASHER (ø13-ZN)	
22	4	600.616	SCREW (M12x35 5739-ZN)	
23	4	600.077	NUT (M12 DIN 980)	
24	2	620.109	HOOK	
25	2	600.075	MUT (M14 DIN 980)	
26	1	230.005	HOSE SUPPORT	Only hydraulic lift version
27	1	620.250	WASHER (ø11/30x2,5-6593 ZN)	Only hydraulic lift version
28	1	600.006	SCREW (M10x25-5739)	Only hydraulic lift version

**TABLE
920.225**

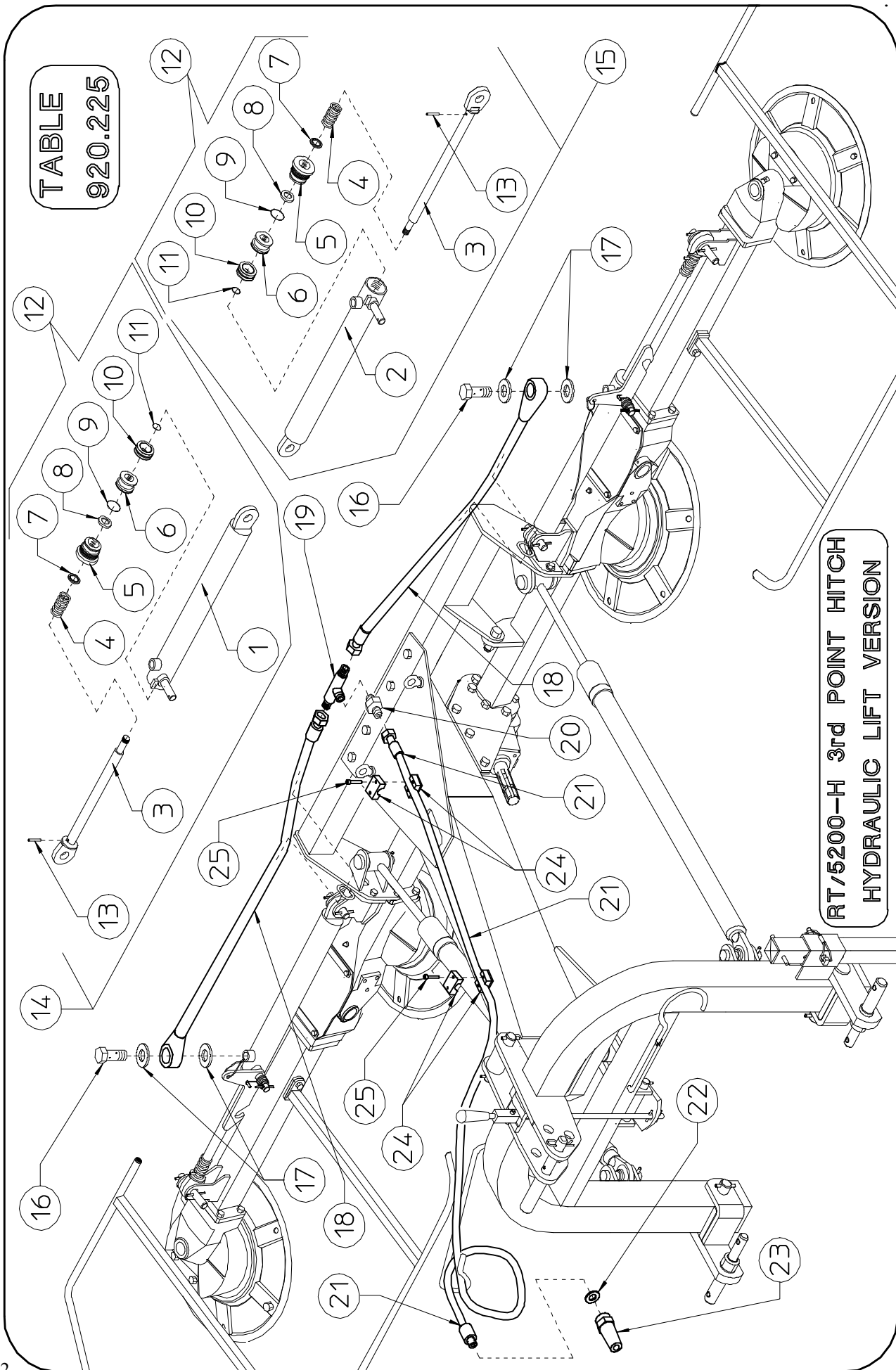

**RT/5200-H 3rd POINT HITCH
HYDRAULIC LIFT VERSION**

RT/5200-H 3rd POINT HITCH - TABLE PART NO 920.225 (HYDRAULIC LIFT VERSION)

ITEM	Q.ty	PART NO	DESCRIPTION	NOTE
1	1	220.829	CYLINDER BARREL, RH	
2	1	220.830	CYLINDER BARREL, LH	
3	2	220.831	ROD	
4	2	200.947	SPRING	
5	2	210.288	CYLINDER HEAD	
6	2	210.289	PISTON	
7	2	610.025	GASKET	
8	2	610.027	GASKET	
9	2	610.026	GASKET	
10	2	610.028	GASKET	
11	2	610.029	GASKET	
12	2	600.895	SET OF GASKET	
13	2	600.106	SPRING PIN (ø3,5x18)	
14	1	220.822	RH CYLINDER, COMPLETE	
15	1	220.823	LH CYLINDER, COMPLETE	
16	2	600.820	FITTING (3/8")	
17	4	600.819	COPPER WASHER (ø1/4")	
18	2	620.321	HOSE (1/4")	
19	1	600.880	"T" ADAPTOR (1/4")	
20	1	600.883	NIPPLE (1/4"-3/8")	
21	1	620.323	HOSE (3/8")	
22	1	600.269	COPPER WASHER (ø1/2")	
23	1	600.273	QUICK COUPLER (1/2")	
24	4	610.035	HALF HOSE COLLAR	
25	4	610.037	SCREW (M6x25 5931-ZN)	

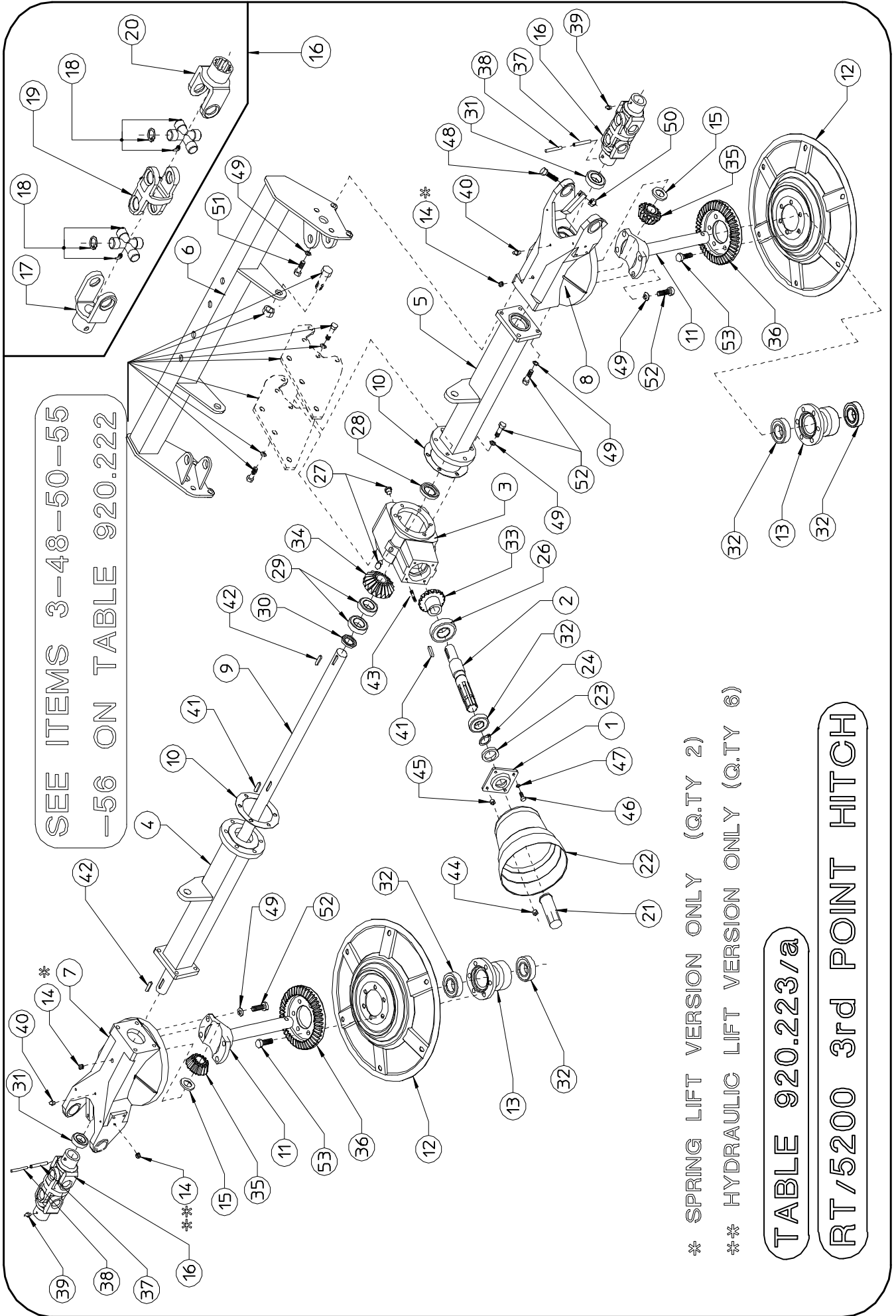

SEE ITEMS 3-48-50-55
-56 ON TABLE 920.222

* SPRING LIFT VERSION ONLY (Q.TY 2)
*** HYDRAULIC LIFT VERSION ONLY (Q.TY 6)

TABLE 920.223/a
RT/5200 3rd POINT HITCH

RT/5200 3rd POINT HITCH - TABLE PART NO 920.223/a (HYDRAULIC AND SPRING LIFT VERSION)				
ITEM	Q.ty	PART NO	DESCRIPTION	NOTE
1	1	200.395	GEARBOX CAP	
2	1	200.396	SHAFT	
3	1	230.225	GEARBOX	
4	1	220.766	RH CENTER AXLE	
5	1	230.003	LH CENTER AXLE	
6	1	220.993	REINFORCEMENT	
7	1	220.652	RH FORK SUPPORT	
8	1	220.653	LH FORK SUPPORT	
9	1	220.527	DRIVE SHAFT	
10	2	200.405	GASKET	
11	2	200.471	PIN	
12	2	220.820	TINE DISC	
13	2	220.836	HUB	
14	2*6	600.896	PLUG	
15	2	200.851	SHIM	
16	2	200.857	JOINT, COMPLETE	
17	2	600.813	FORK	
18	4	600.814	CROSS, COMPLETE	
19	2	600.815	CENTER JOINT	
20	2	600.816	SPLINED FORK	
21	1	600.172	SHAFT GUARD	
22	1	600.681	HOOD	
23	1	600.555	OIL RETAINER (ø35/52x10)	
24	1	600.333	SNAP RING (E35-7435)	
26	1	600.827	BEARING (6209 2RS)	
27	2	600.560	PLUG (3/8")	
28	1	600.561	OIL RETAINER (ø30/62x10)	
29	2	600.579	BEARING (6206)	
30	1	600.582	OIL RETAINER (ø30/56x10)	
31	2	600.609	BEARING (6206 2RS)	
32	5	600.608	BEARING (6207 2RS)	
33	1	200.397	PINION	
34	1	200.400	CROWN	
35	2	200.464	PINION	
36	2	220.774	CROWN	
37	2	600.541	SPRING PIN (ø10x55-6873)	
38	2	600.562	SPRING PIN (ø6x55-6873)	
39	2	600.124	GREASE NIPPLE (M6)	
40	2	600.247	GREASE NIPPLE (M10)	
41	2	600.556	FLAT KEY (B8x7x40-6604)	
42	2	600.559	FLAT KEY (B8x7x30-6604)	
43	2	600.558	BOLT (M8x30-5911)	
44	2	600.037	NUT (M8-5588)	
45	2	600.552	NUT (M8-5587)	
46	2	600.222	SCREW (M8x20-5739)	
47	2	600.228	SPRING WASHER (ø8,4)	
48	4	600.153	SCREW (M12x45-5739)	
49	28	600.049	SPRING WASHER (ø13)	
50	4	600.077	NUT (M12 DIN 980)	
51	4	600.687	SCREW (M12x45-5737)	
52	12	600.615	SCREW (M12x35-5739)	
53	12	600.004	SCREW (M12x30-5739)	

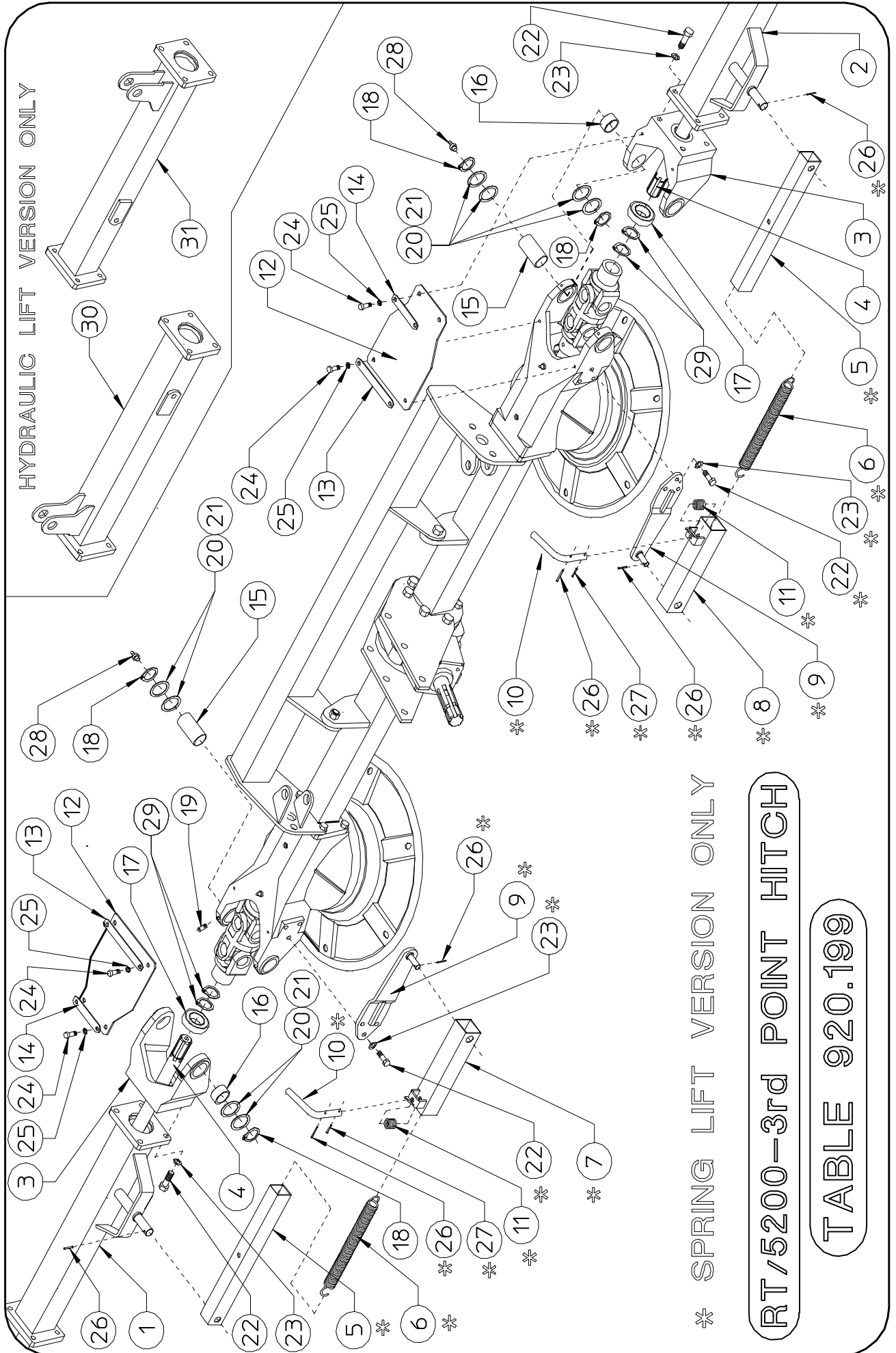

HYDRAULIC LIFT VERSION ONLY

* SPRING LIFT VERSION ONLY

RT/5200-3rd POINT HITCH

TABLE 920.199

RT/5200 -TABLE PART NO 920.199 (SPRING AND HYDRAULIC LIFT VERSION)				
ITEM	Q.ty	PART NO	DESCRIPTION	NOTE
1	1	220.786	RH LATERAL AXLE	Only spring lift version
2	1	220.787	LH LATERAL AXLE	Only spring lift version
3	2	220.651	FORK	
4	2	200.852	LATERAL SHAFT	
5	2	220.776	INNER PIPE	Only spring lift version
6	2	200.772	SPRING	Only spring lift version
7	1	220.777	OUTER RH PIPE	Only spring lift version
8	1	220.778	OUTER LH PIPE	Only spring lift version
9	2	200.927	SPRING HITCH	Only spring lift version
10	2	200.932	PIN	Only spring lift version
11	2	200.280	SPRING	Only spring lift version
12	2	220.810	GUARD	
13	2	220.811	PLATE	
14	2	220.812	PLATE	
15	4	200.850	PIN	
16	4	600.808	BUSH (ø30/34x20)	
17	2	600.609	BEARING (6206 2RS)	
18	8	600.611	SNAP RING (E30-7435)	
19	4	600.809	BOLT (M8x12-5927)	
20	4	200.272	SHIM (ø30,3/39,8x0,5)	
21	4	200.273	SHIM (ø30,3/39,8x1)	
22	14	600.615	SCREW (M12x35-5739)	
23	14	600.049	SPRING WASHER (ø13)	
24	8	600.061	SCREW (M8x16-5739 ZN)	
25	8	600.115	WASHER (ø8,4 ZN)	
26	6	600.539	SPRING PIN (ø6x45-6873)	Only spring lift version
27	2	600.580	SPRING PIN (ø6x26-6873)	Only spring lift version
28	4	600.124	GREASE NIPPLE (M6)	
29	4	620.353	SNAP RING (E29-7435)	
30	1	220.805	RH LATERAL AXLE	Only hydraulic lift version
31	1	220.806	LH LATERAL AXLE	Only hydraulic lift version

SEE ITEM 4 ON TABLE 920.199

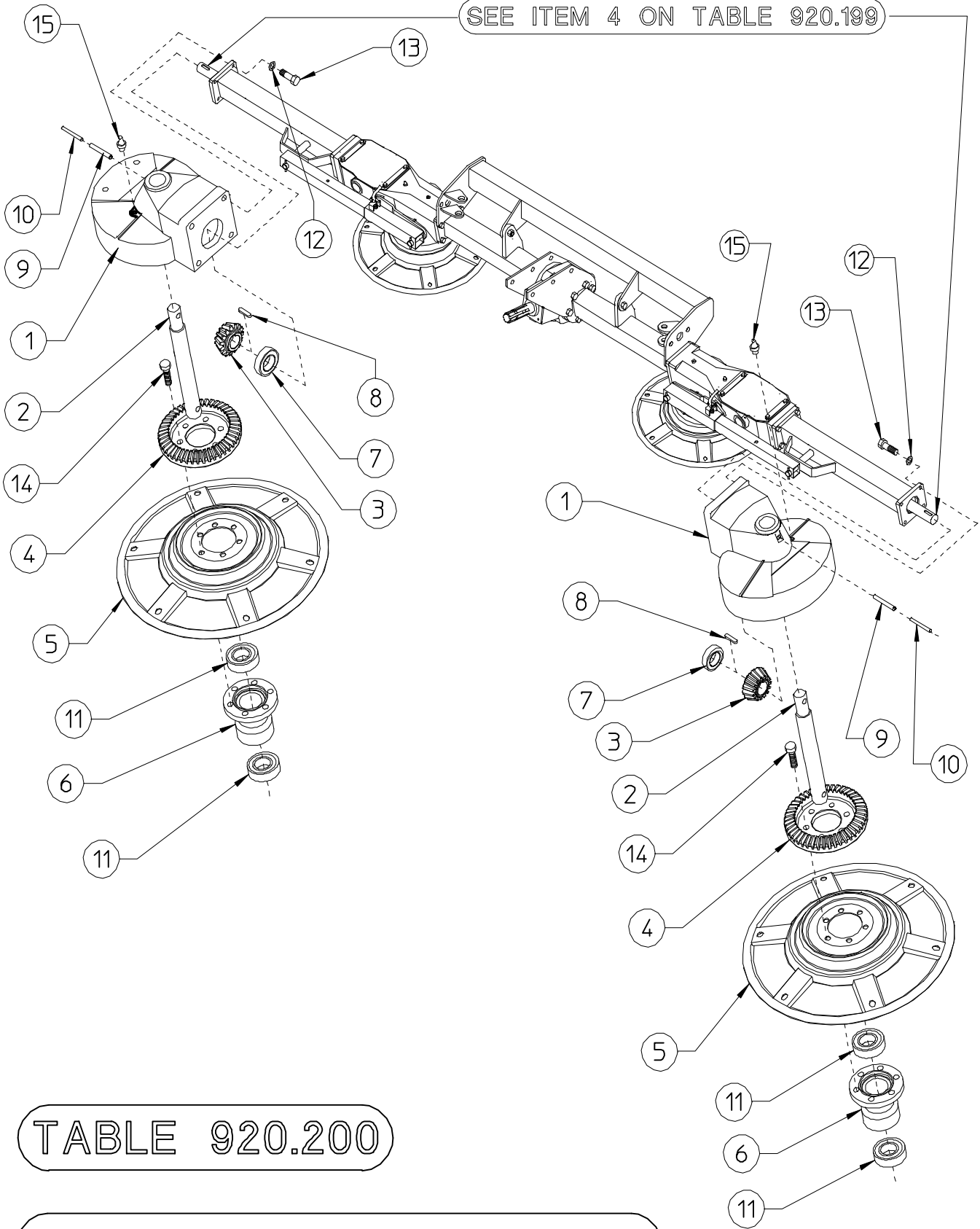

TABLE 920.200

RT/5200 3rd POINT HITCH

RT/5200 -TABLE PART NO 920.200 (SPRING AND HYDRAULIC LIFT VERSION)				
ITEM	Q.ty	PART NO	DESCRIPTION	NOTE
1	2	220.637	GEAR BOX	
2	2	200.407	PIN	
3	2	200.464	PINION	
4	2	220.774	CROWN	
5	2	220.820	TINE DISC	
6	2	220.836	HUB	
7	2	600.609	BEARING (6206 2RS)	
8	2	600.559	FLAT KEY (B8x7x30-6604)	
9	2	600.541	SPRING PIN (ø10x55-6873)	
10	2	600.562	SPRING PIN (ø6x55-6873)	
11	4	600.608	BEARING (6207 2RS)	
12	8	600.049	SPRING WASHER (ø13)	
13	8	600.615	SCREW (M12x35-5739)	
14	12	600.004	SCREW (M12x30-5739)	
15	2	600.247	GREASE NIPPLES (M10)	

RT/5200 3rd POINT HITCH

TABLE 920.226

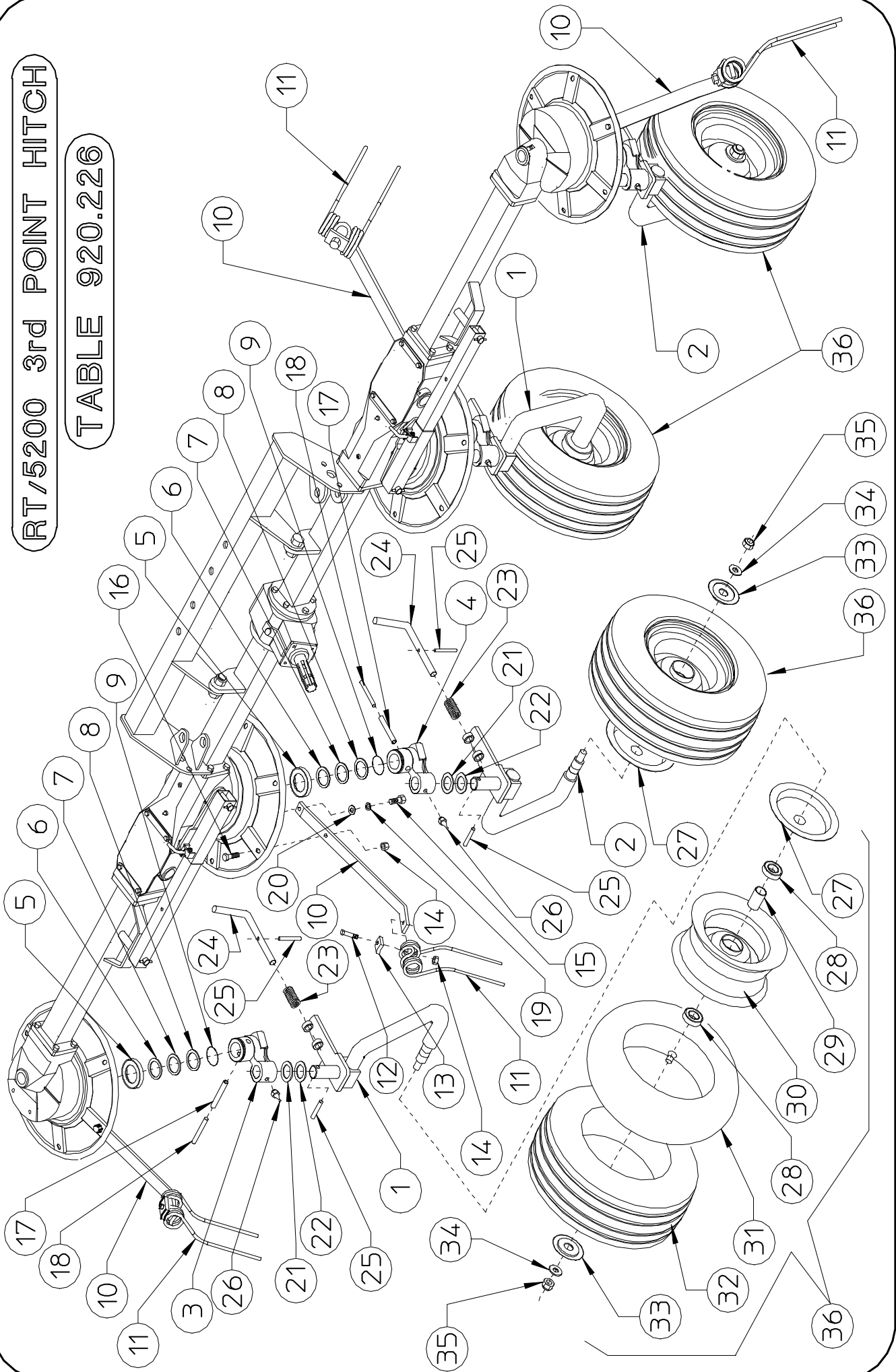

RT/5200 3rd POINT HITCH -TABLE PART NO 920.226 (SPRING AND HYDRAULIC LIFT VERSION)				
ITEM	Q.ty	PART NO	DESCRIPTION	NOTE
1	2	230.205	RH SUPPORT	
2	2	230.206	LH SUPPORT	
3	2	230.009	RH HUB	
4	2	230.010	LH HUB	
5	4	220.821	SPACER	
6	4*	200.419	SHIM (ø35,2/51,8x1)	*Q.ty as required
7	4*	200.274	SHIM (ø35,2/48x0,5)	*Q.ty as required
8	4*	200.490	SHIM (ø35,2/51,8x0,3)	*Q.ty as required
9	4	600.568	GASKET (OR 47,63x3,53)	
10	24	250.402	ARM	
11	24	210.574	TINE	
12	24	620.508	SCREW (M12x45-5737 ZN)	
13	24	200.402	PLATE	
14	48	620.355	NUT (M12-DIN 980)	
15	24	620.788	SCREW (M12x30-5739 ZN)	
16	24	600.616	SCREW (M12x35-5739 ZN)	
17	4	600.541	SPRING PIN (ø10x55-6873)	
18	4	600.562	SPRING PIN (ø6x55-6873)	
19	24	600.018	SPRING WASHER (ø13 ZN)	
20	24	220.864	WASHER (ø12,3/28,5x3)	
21	4*	200.272	SHIM (ø30,3/39,8x0,5)	*Q.ty as required
22	4*	200.273	SHIM (ø30,3/39,8x1)	*Q.ty as required
23	4	200.461	SPRING	
24	4	200.631	PIN	
25	8	600.539	SPRING PIN (ø6x45-6873)	
26	4	600.124	GREASE NIPPLE (M6)	
27	4	210.596	DUST COVER, INNER	
28	8	600.602	BEARING (6205 2RS)	
29	4	200.415	SPACER	
30	4	610.273	RIM	
31	4	610.274	TUBE	
32	4	610.275	TIRE	
33	4	200.416	DUST COVER, OUTER	
34	4	600.031	WASHER (ø17 ZN)	
35	4	600.080	NUT (M16-DIN 980)	
36	4	610.272	TIRE ASSY (16x6,50-8 6PLY)	

CARDAN SHAFT B3 130 E + LW3 - PART NO 610.096 - RT/5200 3rd POINT HITCH

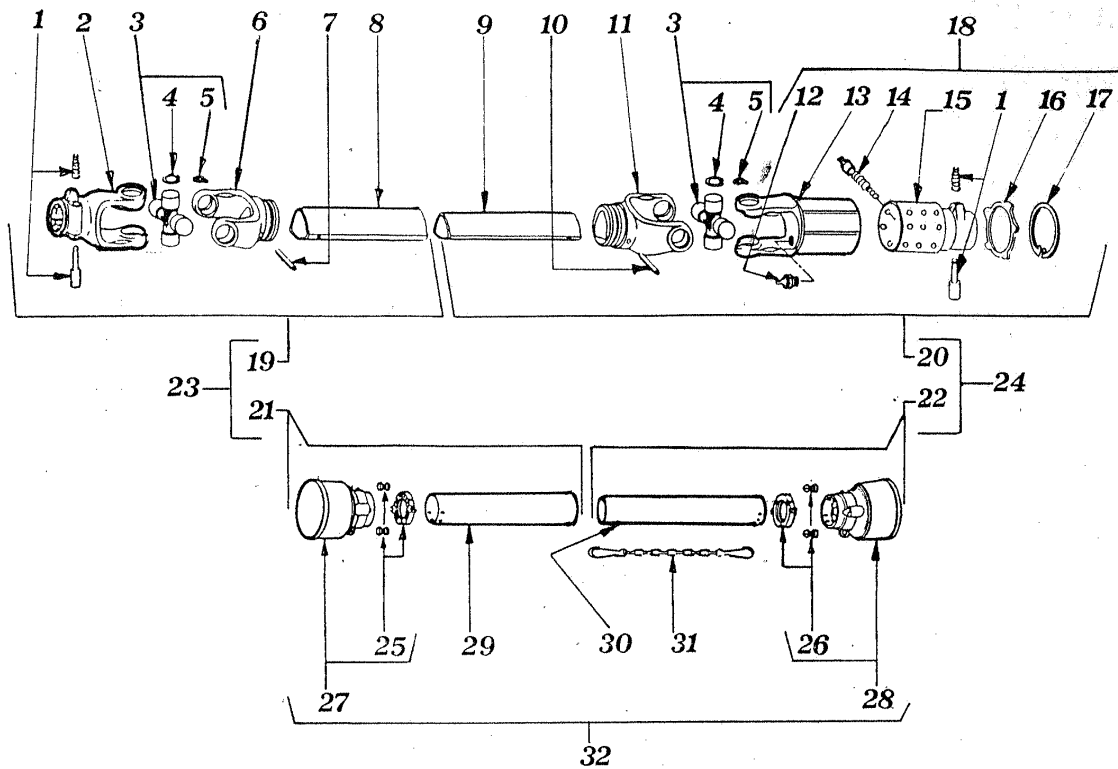

ITEM	PART NO	Q.ty	DESCRIPTION
1	610.057	2	COMPLETE PUSH BUTTON
2	610.071	1	YOKE
3	610.070	2	CROSS JOURNAL ASS.
4	610.205	8	CIRCLIP
5	610.206	2	GREASE NIPPLE
6	610.207	1	OUTER TUBE YOKE
7	610.208	1	FLEXIBLE PIN
8	610.209	1	CM. CARDAN TUBE
9	610.210	1	CM. CARDAN TUBE
10	610.211	1	FLEXIBLE PIN
11	610.212	1	INNER TUBE YOKE
12	610.216	1	GREASE NIPPLE
13	610.217	1	OUTER CASING WITH YOKE
14	610.218	24	RATCHET TOOTH
15	610.219	1	HUB
16	610.220	1	REATING WASHER
17	610.221	1	CIRCLIP
18	610.213	1	TORQUE LW3
19	610.222	1	HALF SHAFT (WITHOUT GUARD)
20	610.223	1	HALF SHAFT (WITHOUT GUARD)
21	610.226	1	HALF SAFETY GUARD
22	610.227	1	HALF SAFETY GUARD
23	610.224	1	HALF SHAFT (WITH GUARD)
24	610.225	1	HALF SHAFT (WITH GUARD)
25	610.078	1	O. BEARING
26	610.079	1	I. BEARING
27	610.080	1	O. BASIC CONE
28	610.081	1	I. BASIC CONE
29	610.214	1	CM. SAFETY TUBE
30	610.215	1	CM. SAFETY TUBE
31	610.068	1	CHaine
32	610.228	1	SAFETY GUARD

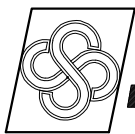

AGRICULTURAL MACHINERY
sitrex® SpA .

Zona Industriale-Viale Grecia, 8
06018 TRESTINA-(Perugia)-ITALY
Tel. +39.075.8540021-Telefax +39.075.8540523
e-mail: sitrex@sitrex.it www.sitrex.com

