

Reversible ploughs

MASTER 183 series



www.kuhn.com



be strong, **be KUHN**



The KUHN plough



The future of farming lies in competitiveness and profitability. The MASTER range concept with its advanced features will contribute to a quick return on your investment.

The Kuhn plough will allow you to:

- Maintain a high quality soil structure with an efficient burial of organic matter and an even aggregate spread throughout the soil profile - crop yields will be increased.
- Have at your disposal a wide range of working width settings and an excellent overall manoeuvrability - "in field" costs will be reduced.
- Benefit from a number of technological innovations such as the reinforced box section, the variable width, the plough structure protection systems (Hydraulic non-stop or traction bolt) - the working life of the plough is increased and maintenance costs reduced.
- Profit from a renowned reliability and long working life allowing you to work throughout the day without interruption - your plough will also keep a high second-hand value.

Opt for a Kuhn plough - because obtaining high yields and optimizing financial results all starts with high quality ploughing.

KUHN offers solutions for ploughing while meeting your requirements with regards to :





MULTI-MASTER 183

A NEW MOUNTED PLOUGH IN 5, 6 AND 7 FURROWS WITH MULTIPLE WORKING WIDTHS. THE TOP OF THE RANGE FOR PLOUGHING PROFESSIONALS

The Multi-Master 183 meets the demands of ploughing professionals:

- Strength and long life with the OPTIDRIVE suspension headstock and the MASTER range concept,
- Safety and comfort with complete plough leg protection in either non-stop hydraulic (NSH) auto-reset or traction bolt system,
- Highly adaptable with high work rates: ease and speed of set-up into work/transport position, ease of adjustments, wide working widths out to a total of 3.55m in one pass.

DRILLED OUT TURNOVER SHAFT IN SPECIAL HEAT-TREATED STEEL

The 140mm diameter drilled out turnover shaft is assembled with conical roller bearings and allows the passage of hydraulic hoses through the centre of the headstock.

This prevents the hoses from twisting during turnover and provides extra protection from possible damage.



WORKING WIDTH ADJUSTMENTS ON THE MULTI-MASTER 183

Multi-Master : 14» - 16» - 18» and 20» by moving bolts to the required width setting hole and by moving the spacers.

FORGED AND HEAT TREATED ONE PIECE MAIN LINK

Designed for strength and long life the main link is assembled with steel bushes and the pins locked to prevent rotation.

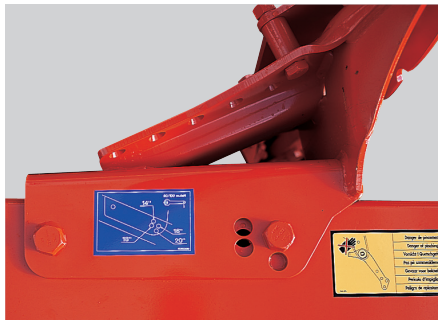
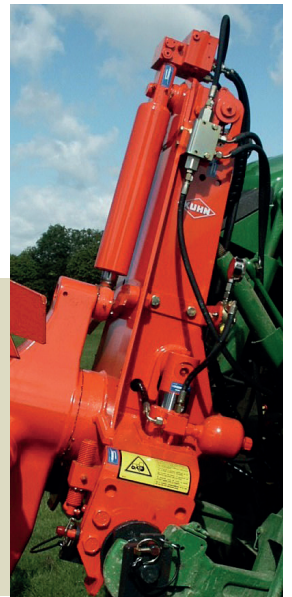

EXCLUSIVE TO KUHN



OPTIDRIVE HEADSTOCK (PATENTED)

The OPTIDRIVE Headstock ensures a flexible link between the tractor and plough. Absorbing shocks during manoeuvres. It constantly protects the tractor top link and the structure of the plough.

EXCLUSIVE TO KUHN



MAIN BEAM

The main beam (180mm) is strengthened by a triangular reinforcement welded along the length of the front section. This gives substantial advantages compared to a conventional plough design.

OL VERSION

The on-land range is designed for tractors fitted with wide-wheels, tracks and dual wheels. The large dimensioned parallelogram system enables this plough range to adapt to tractors with an overall width of up to 3.20m whilst at the same time maintaining the possibility to plough in-furrow. Furrow compaction can be avoided by ploughing on-land, a special concern with the high tractor size used with this range of ploughs.





VARI-MASTER 183

A 5, 6 AND 7 FURROWS MOUNTED PLOUGH, VARIABLE WIDTH WITH NON-STOP HYDRAULIC AUTO-RESET: THE TOP OF THE RANGE FOR PLOUGHING PROFESSIONALS

The Vari-Master 183 meets the demands of ploughing professionals:

- Strength and long life with the OPTIDRIVE suspension headstock and the MASTER range concept.
- Complete plough leg protection with the non-stop hydraulic auto-reset system and transport wheel with suspension.
- Highly adaptable with high work rates : ease and speed of set-up into work/ transport position, ease of adjustments, variable working width to adapt to all work conditions.

EXCLUSIVE TO KUHN

OPTIDRIVE HEADSTOCK :

Made up of 2 cylinders and accumulators connected to an inside double frame allowing shock absorption during manoeuvres. The vertical travel range, generated by the flexibility of the hydraulics, ensures protection of both the tractor and the plough.

The suspension adapts to the weight of the different ploughs by changing the pressure on the Optidrive hydraulic system.

- whilst ploughing, the Optidrive system is automatically locked to monitor the tractor's efforts, which allows optimal work.
- in headlands, the suspension is active, protecting both the tractor and the plough.
- transport: easy to go from working position to transport thanks to the moveable double frame, without adjusting or unhitching the top link.



EXCLUSIVE TO KUHN

COMBINED FRONT FURROW WIDTH/ANGLING



According to the tractor linkages and/or the ground conditions the front furrow width is adjusted to its optimum setting. The parallelogram obtained by the layout of the two linkages means that any adjustment in front furrow width automatically adjusts the angling of the plough so that the tractor always pulls in perfect line. Adjustments are quickly carried out by simply turning the turnbuckle adjuster or by activating the hydraulic cylinder (optional).

One adjustment is sufficient unlike conventional systems where the front furrow width and the plough alignment are separated. With the conventional system as one adjustment interacts with the other, several successive adjustments are necessary.

TRANSPORT WHEEL WITH SUSPENSION

The plough can be transported on the road in complete safety thanks to a 660mm diameter transport wheel equipped with its own suspension system serving to protect the plough and tractor from possible transport shocks. The wheel can be swung into the transport position in a single movement by pulling on a locking pin.



USEFUL ADVANTAGES OF HAVING A VARIABLE WIDTH PLOUGH



- Instant adaptation to available traction.
- Time savings and reduced fuel consumption.
- Holding of a good working speed on steep slopes.
- Ability to cope with different levels of trash.
- Clean finish to the field.
- Avoiding obstacles and tidying up of difficult unploughed areas.



WORKING WIDTH ADJUSTMENTS

12" to 19" in 96cm point to point. The working width is changed hydraulically from the tractor cab. The correction of the front furrow and plough aligning settings are carried out automatically as the width changes. For plough turnover the plough bodies fold up automatically to their narrowest width for the maximum possible ground clearance. After turnover the plough returns to the memorised working width.



EXCLUSIVE TO KUHN

- The whole variable width linkage system is enclosed in the plough structure giving maximum protection from water, dust and possible shocks.
- All moving pivot points are chromed, prevented from rotating and assembled with wearing bushes: no risk of jamming and very low maintenance.

PLOUGH LEG PROTECTION SYSTEMS FOR ALL WORKING CONDITIONS



TRACTION BOLT LEG PROTECTION

Abrupt breakage of the 16mm traction bolt following a force at the plough point in excess of 4000kg avoids risk of too frequent a breakage.

- The bolt **A** runs in the direction of the line of force contrary to the conventional scissor bolt method where the bolt runs across the line of force.
- Due to these “in-line” forces the bolt support never deforms and never becomes rounded with use.
- It is impossible for the bolt **A** to become trapped inside following a breakage. Once a force in excess of 4000kg is met at the furrow point, the bolt breaks along its length and simply falls away for quick and easy replacement.
- Even after many bolt breakages the plough bodies remain at an identical depth and perfectly in-line.



AUTO-RESET PLOUGH LEG PROTECTION NSH



Designed for stony and heavy conditions the non-stop hydraulic system gives a rapid break-away when an obstacle is met and yet an increase in pressure thereafter bringing the body quickly and firmly back into work.

VARIBAR system: An optional system allowing instant control from the tractor cab of the NSH pressure at the share point.

MAXIBAR system: The Maxibar option allows an increase in pressure at the share point to 2500kg. The option is particularly useful in heavy compacted ground.

BENEFITS OF THE NSH SYSTEM:

- Long life and reliability - hydraulic technology is more reliable with no wear or friction and fewer moving parts (just one articulation point and two moving parts per leg).
- Weight saving - compared to a mechanical auto-reset system the NSH system is 25kg lighter per leg.
- Ease of use - the pressure at the share point can be quickly adjusted from 600 to 1300kg by simply inflating or deflating the accumulator mounted on the headstock.
- Excellent performance - plough leg resetting is quick and positive once the obstacle is passed with no “drumming” of the plough bodies in work.
- Compactness - the NSH tie rod is located inside the plough leg structure and the hydraulic cylinder incorporated into the leg profile for the maximum possible clearance and minimum obstruction to trash and vegetation.
- Exceptional obstacle clearance - the share point can lift 60cm vertically out of work and 20cm sideways.

HEAVY DUTY PLOUGH LEG ARTICULATION AND TIE ROD

- All pressure points receive a specific heat treatment process.
- With just one articulation point all the forces put through the plough leg are transmitted in a straight line through a one piece forged and heat treated tie rod.

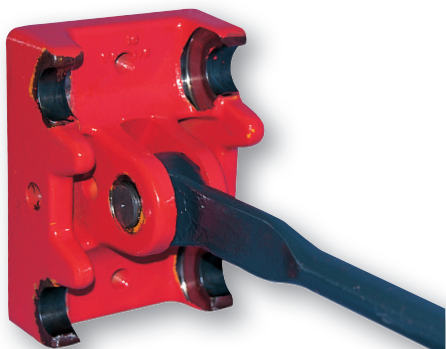

KUHN HAS THE MOST ADVANCED AUTO-RESET SYSTEM ON THE MARKET FOR MAXIMUM CUSTOMER SATISFACTION

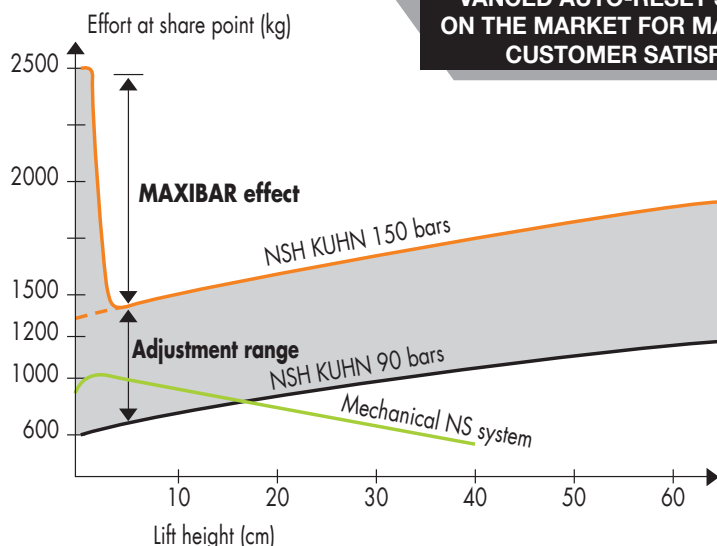

HIGH QUALITY EQUIPMENT

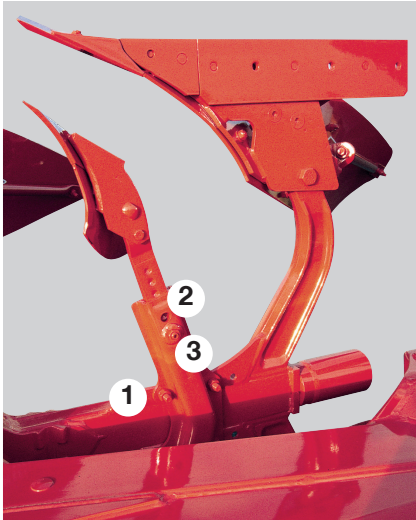

INDEPENDENT, EASY TO ADJUST SKIMMERS

Each skimmer is totally independent left from right and is firmly held in a sheath like support. The skimmers are shear bolt protected and are adjustable in three directions:

- 1 Forwards and backwards - with a choice of three positions the sheath bolts to the leg support via countersunk holes to avoid any risk of free play.
- 2 Up and down - rapid and precise height adjustment (20cm of adjustment) also with countersunk holes in the skimmer leg for easy locking of the leg at the desired height.
- 3 Side to side - for correct adjustment in relation to the disc couler (where fitted).



DISC COULTERS

Discs have a diameter of 500mm plain or notched with the added choice on the traction bolt models of a 600mm disc. The disc serves to cut the furrow wall in front of the plough body giving a cleaner finish and improving trash incorporation.



TRASHBOARD

For trash burial in difficult conditions where the quantity of trash may otherwise block up the skimmers.



ALL PURPOSE ZX SKIMMER

Well adapted to ploughing on cereal or maize stubbles. ZXL : large share, ZXE : small share.



HELICOIDAL ZH SKIMMER

Helicoidal skimmer for deep trash burial. Well adapted to grassland ploughing.



ZRL HIGH CAPACITY SKIMMER

High capacity skimmer for trash incorporation throughout the soil profile. Excellent straw and maize trash burial.

PRESS ARMS WITH HYDRAULIC RELEASE



Available for the complete plough range the arm allows the use of a furrow press with easy hooking up and hydraulic push-off. On the pick-up hook part of the arm where there is most risk of damage all grease nipples and hydraulic hoses are protected inside the structure of the head. The arm folds up conveniently for subsequent transport.



PLOUGH BODIES DESIGNED TO SAVE ON COSTS

1 - MOULDBOARDS WITH UNEQUAL LAYER TRIPLEX STEEL

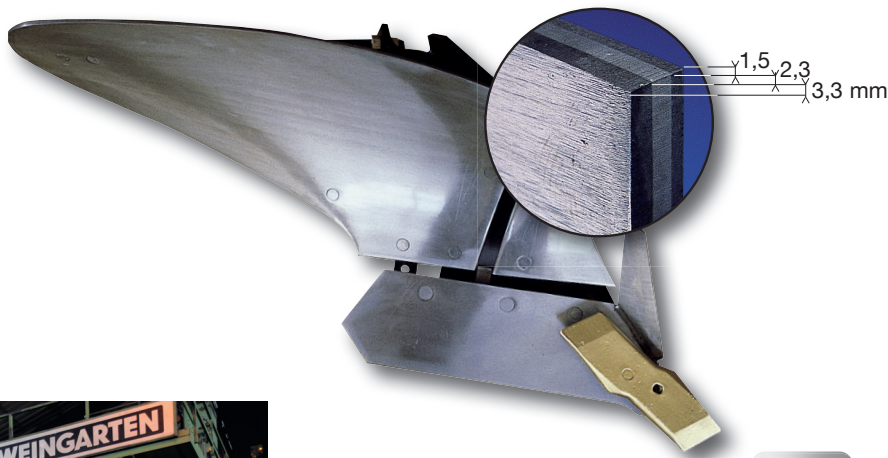

EXCLUSIVE TO KUHN

- Kuhn mouldboards are made of unequal layer Triplex steel.
- The thickness of the wearing surface is increased to 3.3mm - an exclusive feature.



2 - PLOUGH BODIES DESIGNED TO REDUCE WEARING COST



Shares are forged with a force of 5500 tonnes ensuring:

- excellent wear resistance,
- self-sharpening profile due to the grain in the steel resulting from the forging process.



MARATHON®

Special heat treated forged steel. Reversible for maximum efficiency. Featuring a step giving better landside protection.



OLYMPIC®

Special heat treated forged steel. Reversible for maximum efficiency. More pronounced form at wearing zones on the point for longer life and better protection of the landside. Point is self sharpening for good ground penetration at all times.



SUPER MARATHON®

Special heat treated forged steel fitted with a tungsten carbide tip. High wear resistance. Four to five times the life of a traditional share point. A sharp working edge is maintained for excellent ground penetration.





CLASSIC TYPE PLOUGH BODIES

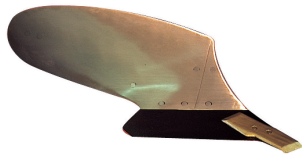

N BODY

Helicoidal cylindrical semi-digger.
15 to 30cm ploughing depth.
Highly versatile body.
Cylindrical at front, helicoidal at rear. Low draft, ensures a partly broken furrow, with excellent trash burial.



L WIDE HELICOIDAL (20 TO 35 CM)

All round body for furrowed or flat ploughing finish depending on the forward speed. Cuts a particularly wide furrow bottom for the passage of wide tractor tyres



VP SLATTED BODY

Mouldboard composed of independant and interchangeable slats. Gives a reduction of traction force, due to a lower mouldboard surface area. Easy maintenance.



MASTER 183 : Comfort, speed and ease of use



DEPTH WHEEL WITH SHOCK ABSORBER

Available in 690 and 760mm diameters with rubber tyre. The shock absorber not only removes the shock of the wheel falling during turnover but also ensures the wheel is in the correct rearwards inclined position as the plough is lowered back into work.



HYDRAULICALLY ADJUSTED DEPTH WHEEL

Available in 690mm diameters the depth wheel can be adjusted hydraulically (by cylinders no directly from the tractor seat.

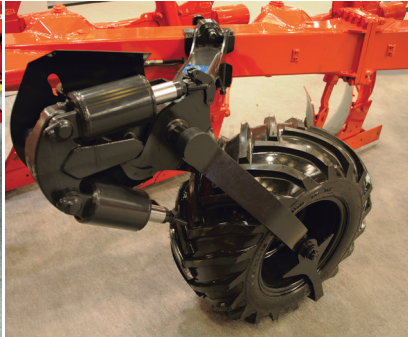

HYDRAULICALLY HD TRONIC ADJUSTED DEPTH WHEEL

Ø 760, 370mm width. Outstanding carrying capacity in difficult conditions. Easier rolling owing to the large diameter and agricultural thread of the wheel.



KTS 201 CONTROL BOX

(only HD TRONIC) indicating the working depth in the cabin.

Specifications

MASTER 183

Model	Beam configuration E : Extensible	Max authorized tractor power (kW/hp)	Traction bolt leg protection				NSH leg protection			
			Weight* (kg)	working width (inches/cm)	Clearances (cm)		Weight* (kg)	working width (inches/cm)	Clearances (cm)	
					under beam	point to point			under beam	point to point
Multi-Master 183	5 E	202/275	2073	14" - 16" 18" and 20" 30 - 40 - 45 and 50 cm	80	96	2230	14" - 16" 18" and 20" 30 - 40 - 45 and 50 cm	80	96
	6 (5E + 1)	243/330	2341				2510			
	7 (5E + 1 + 1)	283/385	2609				-			
Multi-Master 183 OL	5 E	202/275	2273	14" - 16" 18" and 20" 30 - 40 - 45 and 50 cm	80	96	2430	14" - 16" 18" and 20" 30 - 40 - 45 and 50 cm	80	96
	6 (5E + 1)	243/330	2541				2710			
	7 (5E + 1 + 1)	283/385	2809				-			
Vari-Master 183	5 E	202/275	2090	12" to 19" 30 to 48 cm	80	96	2285	12" to 19" 30 to 48 cm	80	96
	6 (5E + 1)	243/330	2355				2560			
	7 (5E + 1 + 1)	283/385	2620				2840			

KUHN HUARD S.A.S.

2, rue du Québec - Zone Horizon - F - 44110 Châteaubriant

KUHN NORTH AMERICA, INC.

1501 West Seventh Avenue - P.O BOX 167 - Brodhead, WI 53520 - USA

KUHN FARM MACHINERY PTY. LTD

313-325 Foleys road - Deer Park, 3023 Victoria AUSTRALIA

KUHN FARM MACHINERY (U.K.) LTD

Stafford Park 7 - GB TELFORD/SHROPS TF3 3BQ

For more information about your nearest KUHN dealer, visit our website www.kuhn.com



Your KUHN dealer

www.kuhn.com

Some machines have a considerable weight. Respect the tractor gross vehicle weight rating, its lift capacity and maximum load per axle. The tractor front axle load must always reach minimum 20 % of the tractor net weight. Our material is produced in accordance with the European Machinery Directive in the member states of the European Union. In countries outside the E.U., our machinery complies with the safety regulations set by the country concerned. Some safety devices may have been removed from our leaflets in order to clarify the illustration. Under no circumstances should the machine be operated without the necessary safety devices in place (as specified by the assembly instructions and operators manual). We reserve the right to change any designs, specifications or materials listed without further notice. Machines and equipment in this document can be covered by at least one patent and/or registered design. Trademarks cited in this document may be registered in one or several countries.

Also find KUHN on

