

Soil Looseners

CULTISOIL DC 301 - 401



www.kuhn.com



be strong, be **KUHN**

KUHN SOIL LOOSENERS

THE KUHN CULTISOIL ENABLES YOU:

- To obtain optimum seedbeds in order to favour plant development - maximised productivity.
- To have a versatile tool at your disposal which is adapted for conventional techniques and minimum tillage applications, and providing great comfort of use – reduced operating costs and maintenance.
- To benefit from useful innovations which result from taking your requirements into consideration.
- To use equipment where reliability and longevity are renown - minimise delays during soil preparation jobs and retain a high resale value.

Profitability depends on the performance and the reliability of your equipment to produce quality crops. That is why choose the KUHN CULTISOIL to meet these criteria.

KUHN offers solutions for soil preparation while meeting your requirements in terms of:





KUHN

COMBILINER

HR 304

KUHN

ROBUST, COMPACT... VERSATILITY TO ADAPT TO VARIOUS WORKING METHODS



The CULTISOIL soil looseners of the latest generation will be efficient and performing allies in conventional soil preparation techniques and minimum tillage applications.

Particular care has been given to 4 fundamental criteria:

- Efficiency and respect of the soil structure.
- Simple and easy adjustments enabling to adapt to all working conditions.
- Maintenance and costs reduced to the minimum.
- High reliability and longevity for your peace of mind.



EFFICIENCY: HIGH CAPACITY LINKAGE

The triangular design and important box section (160 x 160mm) high tensile beams provide great robustness and effort resistance to the chassis.

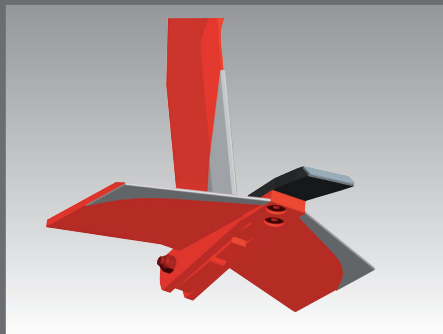

LASTING PERFORMANCES

The legs and wing inner sides have a carbide coating applied by welding. The share tips are fitted with a robust carbide plate for:

- very long service life.
- entry capacity in hard soils.
- good stability at work.

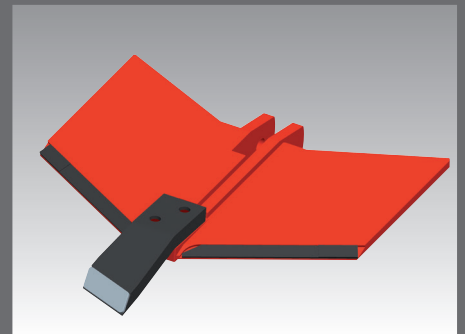

CARBIDE PLATES FOR MAXIMUM SERVICE LIFE

On request, the share wings can also be fitted with carbide plates. Maximum service life, not recommended in stony conditions.



EXCEPTIONAL COMPACTNESS

Thanks to the pivot points and the specific parallelogram, this tool forms a very compact unit. Indeed, for transport and during manoeuvres, the offset is increased by 45 cm only.



CULTISOIL: EASY TO COMBINE AND ADJUST

The parallelogram connecting the CULTISOIL and the rear tool is made up of an adjustable upper straight rod for an easy and rapid adjustment of both machines. The geometry of the parallelogram is respected and enables a balanced functioning of the unit.



IN SOLO: FITTED WITH A ROLLER TO CONTROL THE WORKING DEPTH

From 10 to 35 cm (4" to 14"): the DC is quickly adapted to the needs. For example, to loosen the soil after stubble clearing or minimum tillage, or to break up the tillage pan. With a Maxicrumbler, Maxipacker or PK2 roller.



REDUCE THE NUMBER OF RUNS

The CULTISOIL combined with a cultivation tool enables to carry out simultaneously soil loosening and seedbed preparation. Reduced number of runs and erosion while respecting the soil structure.

AGRONOMICAL STRONG POINTS WHICH MAKE THE DIFFERENCE

CAREFUL DESIGN FOR AN AGRONOMICAL RESULT

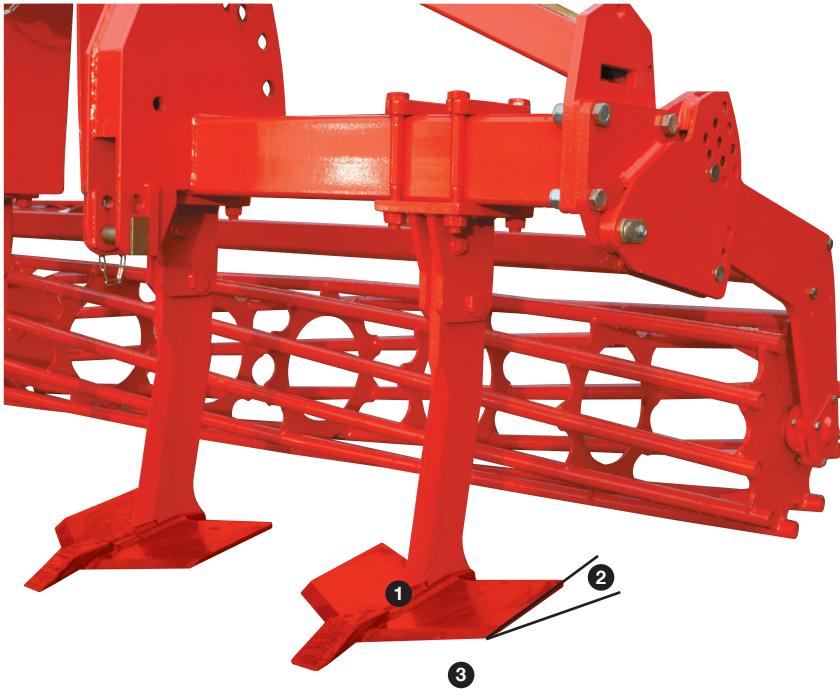

1 Loosening the compact area.

By a "wave" effect created thanks to the specific share dimensions: restructuration of the soil which is lifted and drops behind the share.

2 The share leg angle ensures that the soil's stratification is preserved:

- no mixing between the various soil layers,
- no stones or soil blocks are pulled out,
- the top soil is preserved

3 Homogeneous work over the whole width thanks to the symmetrical form of the share while using a limited number of blades: quality work is ensured.

FOR EACH SITUATION, THE CULTISOIL CAN BE ADAPTED PRECISELY...

With the distance between shares:

- ≈ 50 cm/20": for soils which are not very consistent (sandy, silty soils) or for shallow loosening.
- ≈ 70 cm/28": for very consistent soils (clayey soils) or in plant residues.

With the share width:

- Standard share (45 cm/18"): for top soil work,
- Narrow share (28 cm/11"): for the most compacted soils and very consistent soils (clayey) but also for deep work in order to restructure a bigger soil volume with less power requirement.

Ideal for deep work down to 35 cm

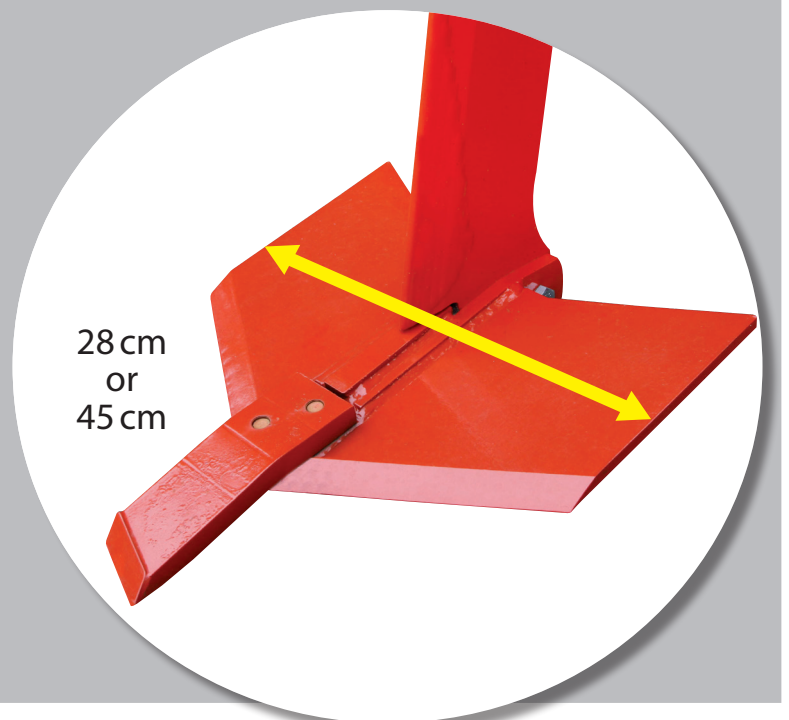

A SOIL ENERGIZER!

GIVE YOUR CROPS EVERY OPPORTUNITY TO SUCCEED: MAXIMISE YOUR YIELDS WHILE REDUCING OPERATING COSTS!

Good soil preparation:

- favours mineralisation of soil mineral substances, especially nitrogen.
- strengthens crops making them more resistant to diseases.
- Improves water circulation for improved capacity to build up reserves or drain excess.
- Contribute to good root development for maximum phytomass production.

THE "WAVE" EFFECT: FOR IMPROVED SOIL LIFE

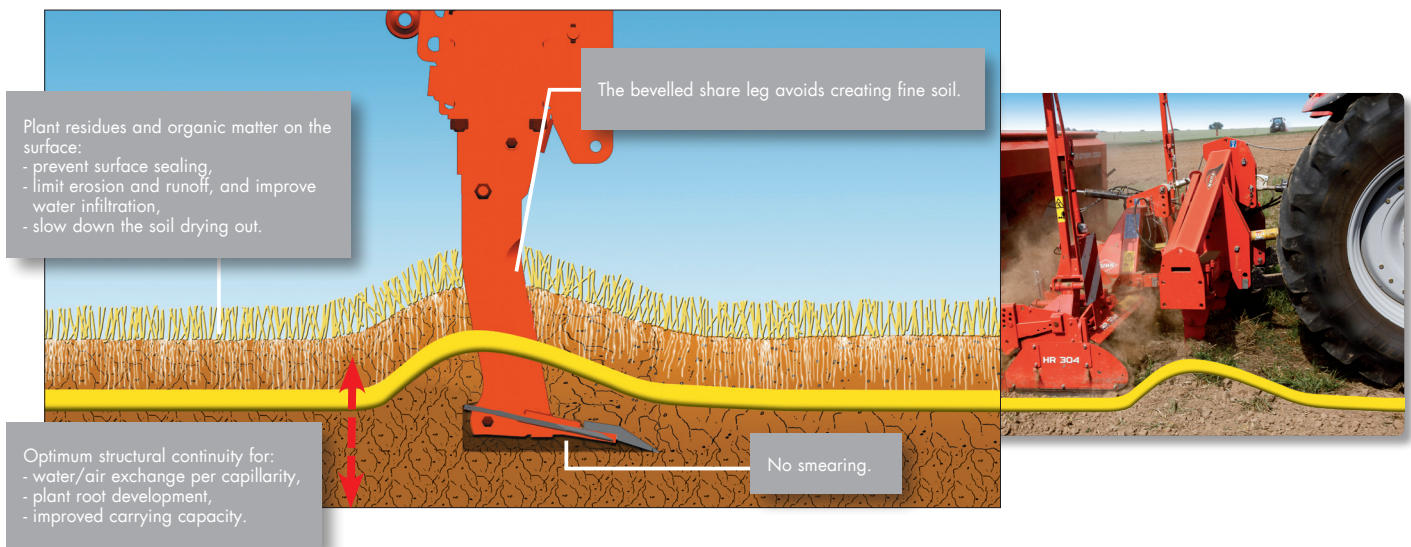

Technical specifications	CULTISOIL DC 301	CULTISOIL DC 401
Working width (m/ft)	3.00 / 9'10"	4.00 / 13'1"
Transport width (m/ft)	2.95 / 9'8"	3.76 / 12'4"
Clearance (cm/inches)	80 / 31	
Number of shares	4 or 6	6 or 8
Share width (cm/inches)	28 or 45/11 or 18 depending on equipment required	
Working depth (cm/inches)	From 10 to 35 / 4 to 14	
Protection against share wear	As standard: Carbide tungsten coating on the leg, share and share point. Optional: share wings fitted with carbide plates	
Safety on each share	Shear bolt safety with anti-wearing bush	
Minimum power requirement when used solo (kW/hp)	73/100	93/130
Minimum power requirement when used in combination (kW/hp)	95/130	117/160
Attachment	Cat. 2 and 3	
Machine weight with parallelogram (kg/lbs)	With 4 shares: 785 / 1731 With 6 shares: 865 / 1907	With 6 shares: 985 / 2172 With 8 shares: 1035 / 2282
Weight of the Maxicrumbler roller kit (kg/lbs)	402 / 886	547 / 1206
Weight of the Maxipacker roller kit (kg/lbs)	627 / 1382	772 / 1702

Optional equipment: set of 2 additional shares – Lengthened PTO for combinations with power harrows or power tillers – Attachment arms for power harrow or power tiller – Link arms to the rear roller (Maxicrumbler, Maxipacker or PK2) – Lateral depth control wheel kit – share wings fitted with carbide plates – hydraulic hose extension.

CULTISOIL IN YOUR COMBILINER

The made to measure drilling combination, for establishing your cultivations in the best conditions, while saving on the series of run.

STUBBLE CULTIVATION RANGE

	OPTIMER+	DISCOVER	DISCOLANDER	CULTIMER	PERFORMER
Working width (m/ft)	3/9'10" to 7.5/24'7"	3,40/11'1" to 5,20/17'	3.70/12'1" to 6/19'7"	3/9'10" to 6/19'7"	4/13' to 7/22'9"
Transport width (m/ft)	3/9'10" to 4/13'	< 2,65/8'8"	2.55/8'3"	2.82/9'2" to 3.50/11'4"	3/9'10"
Number of discs or tines	24 to 60 discs	28 to 44 discs	32 to 52 discs	10 to 19 tines	14 to 26 tines
Recommended working depth (cm)	3 to 10	5 to 18	5 to 18	5 to 35	10 to 35
Mounted or trailed version	Mounted and Trailed	Trailed	Trailed	Mounted and Trailed	Trailed

Discover KUHN's disc or tine stubble cultivator range



1. OPTIMER+ 2. DISCOVER 3. DISCOLANDER 4. CULTIMER L 5. PERFORMER

For more information about your nearest KUHN dealer, visit our website
www.kuhn.com



Visit us on our YouTube channels.



www.kuhn.com

Your KUHN dealer

KUHN HUARD S.A.

2, rue du Québec - Zone Horizon
F-44110 Châteaubriant - FRANCE

KUHN NORTH AMERICA, INC.

1501 West Seventh Avenue - Brodhead,
WI 53520 - USA

KUHN FARM MACHINERY PTY. LTD

313-325 Foleys Road - Deer Park, VIC, 3023 - AUSTRALIA

KUHN FARM MACHINERY (U.K.) LTD

Stafford Park 7 - GB TELFORD/ SHROPS TF3 3BQ

Information given in this document is only for information purposes and is non-contractual. Our machines are in compliance with regulations in force in the country of delivery. In our literature, and for improved illustration of certain details, some safety devices may not be in operating position. When operating these machines, these devices must be in position in accordance with the requirements indicated in the operator's manuals and assembly manuals. Respect the tractor gross vehicle weight rating, its lift capacity and maximum load per axle and tyres. The tractor front axle load must always comply with the regulations of the country of delivery (In Europe, it must reach minimum 20 % of the tractor net weight). We reserve the right to change any designs, specifications or materials listed without further notice. Machines and equipment in this document can be covered by at least one patent and/or registered design. Trademarks cited in this document may be registered in one or several countries.

Also find KUHN on

